

● BLAUPUNKT

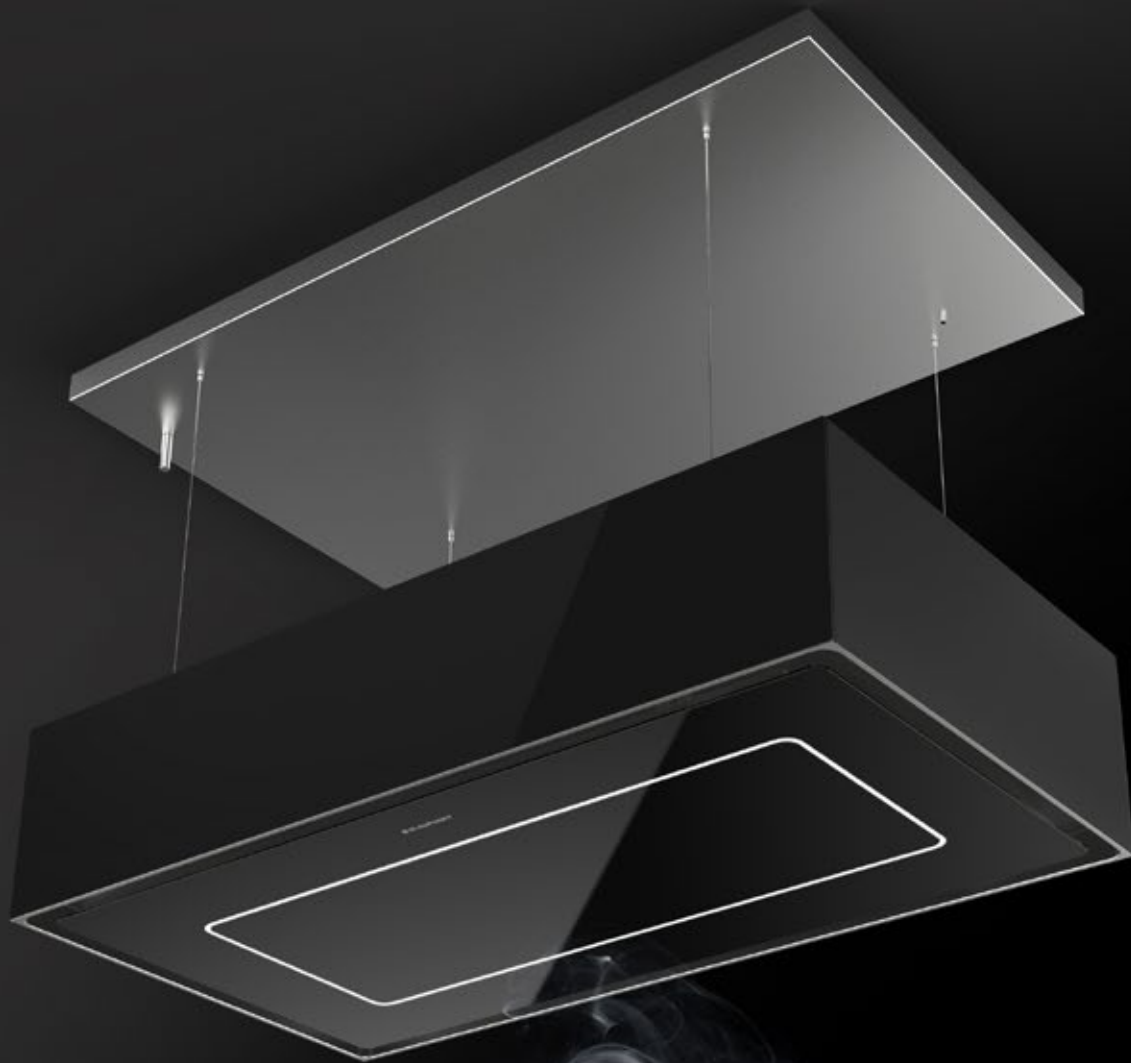

Enjoy it.

Built-in appliances 2023





Perfectly integrated

Those opting for a modern, state-of-the-art kitchen expect not only appliances that meet the latest technical standards, but also a harmonious overall impression that perfectly combines technology and design. Blaupunkt products offer precisely that.

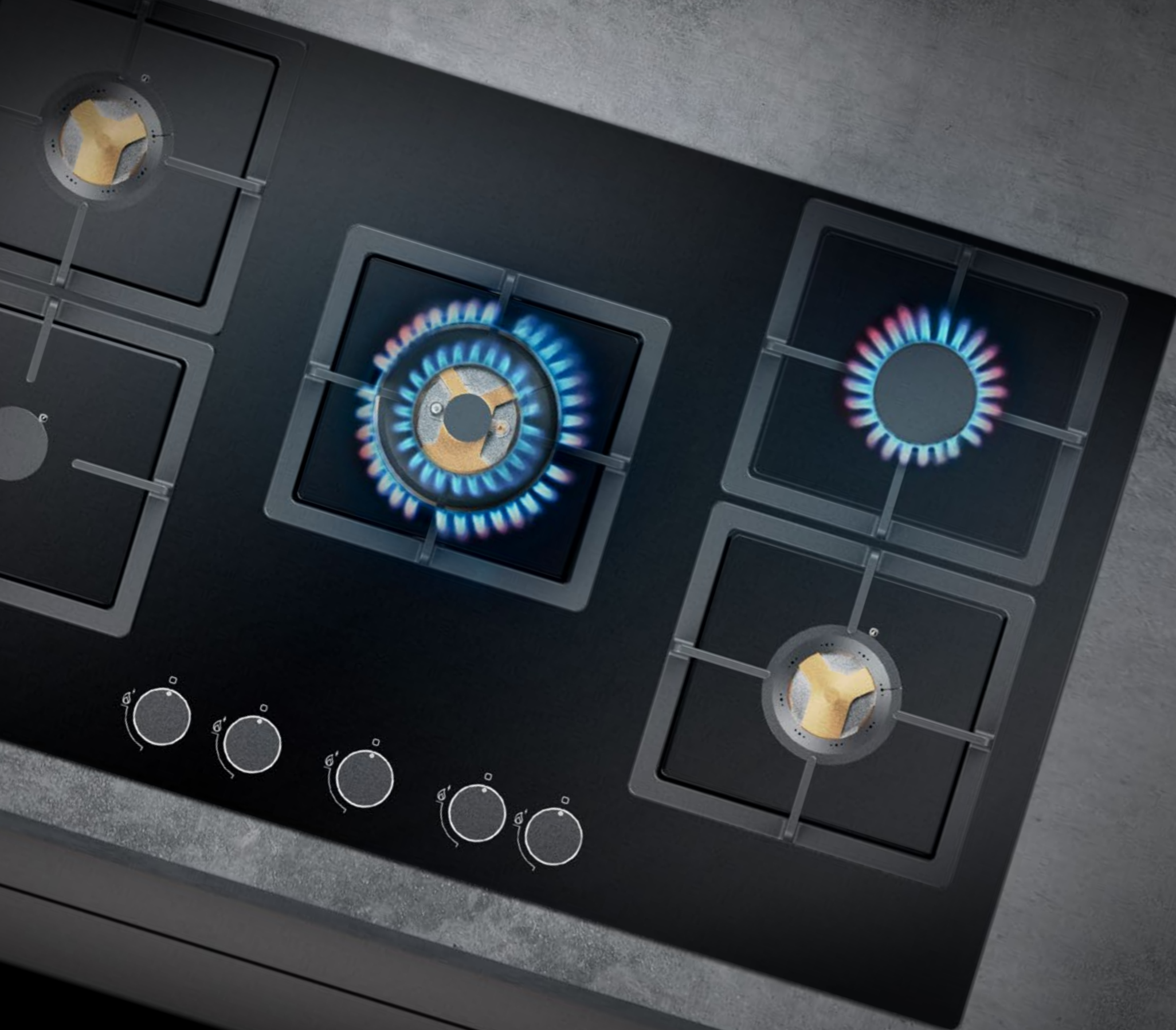

Heat

| | |
|-------------------------|-------|
| Dark Steel | 8–10 |
| Ovens | 14–15 |
| Microwaves | 16–17 |
| Hobs | 20–22 |
| Blaupunkt Multi Control | 24–25 |
| Gas hobs | 28–32 |
| Hobs with extractor fan | 36–41 |

Air

| | |
|---------------|-----------|
| Island hoods | 44, 46–47 |
| Vertical hood | 45 |
| Oblique hoods | 45, 48 |
| Wall hoods | 49–51 |
| Flat hood | 52 |
| Ceiling fans | 53 |

Water

| | |
|---|----|
| Dishwasher, 60 cm, fully integrated | 56 |
| Dishwasher, 60 cm, partially integrated | 57 |

Cold

| | |
|--|-------|
| Freezer | 60 |
| Refrigeration | 60 |
| Refrigerations / freezer combinations | 61–62 |
| Undercounter refrigeration | 63 |
| Freestanding refrigerations / freezer combinations | 64–65 |
| Built-in wine cooler | 66–67 |
| Undercounter wine cooler | 68–69 |
| Freestanding wine cooler | 70 |

| | |
|--------------------|-------|
| Technical drawings | 74–81 |
| Icon explanation | 82–83 |
| Blaupunkt Service | 84 |



DARK STEEL

The Dark Steel series presents itself in a coherent and consistent design. The appliances are carefully aligned to create you a comfortable kitchen space. Ovens and compact appliances can be combined in various ways – along clear, uniform lines of design with black glass and white displays.

Built-in oven with microwave

5B60M 8690GB

**Output, consumption**

- Voltage: 230 V
- Total connected load: 2.9 kW
- 800 W Microwave
- Grill output: 2,200 W / hot air output: 1,800 W

Oven type, heating type

Built-in electric oven with 12 heating types:

- Top / bottom heat
- Bottom heat
- Hot air
- Circulation
- Circulation grill
- Vario large area grill
- Vario small area grill
- Pizza level
- Defrost function
- Dough process
- Microwave with 5 power levels: 80 W, 240 W, 400 W, 560 W, 800 W
- Combined operation

Design, comfort

- Control panel in the Dark Steel design
- Touch Control
- Smart Slider
- Digital display in white
- Quick heating
- Temperature recommendation
- 16 automatic programmes
- Electronic temperature regulation from 30°C – 250°C
- Full glass inner door
- Dark Steel metal handle with logo
- Cooking chamber volume 72 l
- Flat oven walls with oven racks
- Enamelled cooking chamber
- Removable oven door for easy cleaning
- LED oven lighting
- Safety switch-off
- Child protection
- Cooling fan

Accessories

- Combination grate
- Enamelled baking tray

Dimensions H × W × D

- Appliance dimensions: 59.5 × 59.5 × 56.5 cm
- Installation dimensions: 60.0 × 56.0 × 55.0 cm
- Panel height: 96 mm



Built-in oven with steam function

5B90S 8990GB

**Output, consumption**

- Voltage: 220 – 240 V
- Total connected load: 3.15 kW

Oven type, heating type

Built-in electric oven with 12 heating types:

- Top / bottom heat
- Bottom heat
- Hot Air Eco
- Hot air
- Circulation
- Circulation grill
- Vario large area grill
- Vario small area grill
- Pizza level
- Defrost function
- Dough process
- Steam support

Design, comfort

- Control panel in the Dark Steel design
- Touch Control
- Smart Slider
- Digital display in white
- Push & pull water tank
- Temperature sensor
- Quick heating
- Temperature recommendation
- 13 automatic programmes
- Electronic temperature regulation from 30°C – 250°C
- Full glass inner door
- Soft-moving door
- Dark Steel metal handle with logo
- Cooking chamber volume 72 l
- Flat oven walls with oven racks
- Enamelled cooking chamber
- Removable oven door for easy cleaning
- LED oven lighting
- Safety switch-off
- Child protection
- Cooling fan
- Large oven interior with 1-way telescopic extension

Accessories

- Combination grate
- Enamelled baking tray
- Temperature sensor

Dimensions H × W × D

- Appliance dimensions: 59.5 × 59.5 × 56.5 cm
- Installation dimensions: 60.0 × 56.0 × 55.0 cm
- Panel height: 96 mm



Built-in oven with pyrolysis

5B50P 8590GB

**Output, consumption**

- Voltage: 220 – 240 V
- Total connected load: 3.2 kW

Oven type, heating type

Built-in electric oven with 11 heating types:

- Top / bottom heat
- Bottom heat
- Hot Air Eco
- Hot air
- Circulation
- Circulation grill
- Vario large area grill
- Vario small area grill
- Pizza level
- Defrost function
- Dough process

Design, comfort

- Control panel in the Dark Steel design
- Touch Control
- Smart Slider
- Digital display in white
- Quick heating
- Temperature recommendation
- Electronic temperature regulation from 30°C – 250°C
- Pyrolytic self-cleaning
- Full glass inner door
- Soft-moving door
- Dark Steel metal handle with logo
- Cooking chamber volume 72 l
- Flat oven walls with oven racks
- Enamelled cooking chamber
- Removable oven door for easy cleaning
- Oven lighting
- Safety switch-off
- Child protection, door lock in pyrolysis mode
- Cooling fan
- Large oven interior with 1-way telescopic extension

Accessories

- Combination grate
- Enamelled baking tray

Dimensions H × W × D

- Appliance dimensions: 59.5 × 59.5 × 56.5 cm
- Installation dimensions: 60.0 × 56.0 × 55.0 cm
- Panel height: 96 mm



Built-in oven

5B50N 8590GB New

**Output, consumption**

- Voltage: 220 – 240 V
- Total connected load: 2.9 kW

Oven type, heating type

Built-in electric oven with 11 heating types:

- Top / bottom heat
- Bottom heat
- Hot Air Eco
- Hot air
- Circulation
- Circulation grill
- Vario large area grill
- Vario small area grill
- Pizza level
- Defrost function
- Dough process

Design, comfort

- Control panel in the Dark Steel design
- Touch Control
- Smart Slider
- Digital display in white
- Quick heating
- Temperature recommendation
- Electronic temperature regulation from 30°C – 250°C
- Full glass inner door
- Soft-moving door
- Dark Steel metal handle with logo
- Cooking chamber volume 72 l
- Flat oven walls with oven racks
- Enamelled cooking chamber
- Removable oven door for easy cleaning
- Oven lighting
- Safety switch-off
- Child protection, door lock in pyrolysis mode
- Cooling fan
- Large oven interior with 1-way telescopic extension

Accessories

- Combination grate
- Enamelled baking tray

Dimensions H × W × D

- Appliance dimensions: 59.5 × 59.5 × 56.5 cm
- Installation dimensions: 60.0 × 56.0 × 55.0 cm
- Panel height: 96 mm



Combination steam cooker

5C90S 8990GB

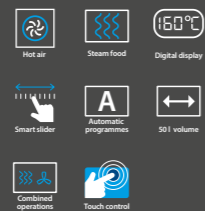
**Output, consumption**

- Voltage: 220–240 V
- Total connected load: 3.0 kW
- Grill output: 2,200 W / hot air output: 1,700 W

Oven type, heating type

Compact oven with 13 heating types:

- Top / bottom heat
- Bottom heat
- Hot Air Eco
- Hot air
- Circulation
- Circulation grill
- Vario large area grill
- Vario small area grill
- Pizza level
- Defrost function
- Dough process
- Steam cooking from 35 °C–100 °C
- Combined operation

Design, comfort

- Control panel in the Dark Steel design
- Touch Control
- Smart Slider
- Digital display in white
- Push & pull water tank
- Temperature sensor
- Quick heating
- Temperature recommendation
- 16 automatic programmes
- Electronic temperature regulation from 30 °C–250 °C
- Full glass inner door
- Dark Steel metal handle with logo
- Cooking chamber volume 50 l
- Flat oven walls with oven racks
- Enamelled cooking chamber
- Removable oven door for easy cleaning
- LED oven lighting
- Safety switch-off
- Child protection
- Cooling fan

Accessories

- Combination grate
- Enamelled baking tray
- XL steam cooking container, perforated
- Temperature sensor

Dimensions H × W × D

- Appliance dimensions: 45,4 × 59,5 × 56,8 cm
- Installation dimensions: 45,0 × 56,0 × 55,0 cm
- Panel height: 96 mm



Warming drawer

5WS 16400

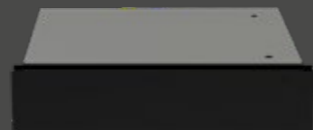
**Output, consumption**

- Voltage: 220–240 V
- Total connected load: 0.4 kW

Oven type, heating type

- Heating by fan heater
- Temperature regulation in 3 levels: from 30 °C–80 °C
- 20.5 l interior volume
- Rotary switch on inside

Design, comfort

- Black glass front
- Opens without handles by push & pull
- Telescopic full extension
- Anti-slip mat
- Dish pre-heating
- Food warm-keeping function
- Defrosting of frozen food
- Load capacity 15 kg

Dimensions H × W × D

- Appliance dimensions: 14,0 × 59,4 × 54,2 cm
- Installation dimensions: 14,0 × 56,0–56,8 × 55,0 cm





OVENS

Crispy, delicate and fresh – all available with a simple touch! Intuitive operating concepts and clearly arranged display solutions allow your oven to produce perfect results. And when the feast is over, these practical kitchen appliances simply clean themselves.

Built-in oven

5B36N 0250IN

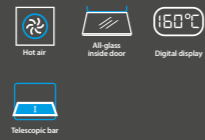
**Output, consumption**

- Voltage: 220 – 240 V
- Total connected load: 3.0 kW

Oven type, heating type

Built-in electric oven with 8 heating types:

- Top / bottom heat
- Bottom heat
- Hot air Eco
- Hot air
- Hot air-Grill
- Vario large area grill
- Vario small area grill
- Defrost function

Design, comfort

- Fully retractable control knob
- Digital display
- Electronic clock
- Quick heating
- Temperature recommendation
- Full glass inner door
- Metal handle
- Cooking chamber capacity 70 l
- Smooth oven walls with suspended grates
- Enamelled cooking chamber
- Removable oven door for easy cleaning
- Oven lighting
- Safety switch-off
- Cooling fan
- Large oven interior with 1-way telescopic extension

Accessories

- Enamelled baking tray
- Combination grate

Dimensions H x W x D

- Appliance dimensions: 59.5 x 59.5 x 57.5 cm
- Installation dimensions: 59.0 x 56.0 x 55.0 cm
- Panel height: 96 mm



Built-in oven

5B30N 0250IN New

**Output, consumption**

- Voltage: 220 – 240 V
- Total connected load: 3.0 kW

Oven type, heating type

Built-in electric oven with 8 heating types:

- Top / bottom heat
- Bottom heat
- Hot Air Eco
- Hot air
- Hot air grill
- Vario large area grill
- Vario small area grill
- Defrost function

Design, comfort

- Fully retractable control knob
- Digital display
- Electronic clock
- Quick heating
- Temperature recommendation
- Full glass inner door
- Metal handle
- Cooking chamber volume 70 l
- Flat oven walls with oven racks
- Enamelled cooking chamber
- Removable oven door for easy cleaning
- Oven lighting
- Safety switch-off
- Cooling fan
- Large oven interior with 1-way telescopic extension

Dimensions H x W x D

- Appliance dimensions: 59.5 x 59.5 x 57.5 cm
- Installation dimensions: 59.0 x 56.0 x 55.0 cm
- Panel height: 96 mm



Built-in oven

5B20N 0290IN

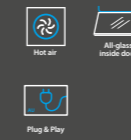
**Output, consumption**

- Voltage: 220 – 240 V
- Total connected load: 2.1 kW

Oven type, heating type

Built-in electric oven with 5 heating types:

- Hot Air
- Grill
- Grill with fan
- Defrosting
- ECO

Design, comfort

- Temperature regulation from 50 °C – 250 °C
- Full glass inner door
- Low window temperature
- Cooking chamber volume 70 l
- Smooth oven walls with suspended grates
- Metal handle
- Enamelled cooking chamber
- Removable oven door for easy cleaning
- Oven lighting
- Cooling fan
- Control lamp for operation condition

Dimensions H x W x D

- Appliance dimensions: 59.5 x 59.5 x 57.5 cm
- Installation dimensions: 60.0 x 57.0 x 56.0 cm
- Panel height: 120 mm



Built-in compact microwave oven

5MG 17190IN

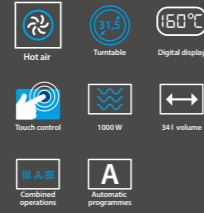
**Output, consumption**

- Voltage: 230 – 240 V
- Connected load: 2.3 kW
- 1,000 W Microwave
- Grill Power: 1,100 W
- Hot air Power: 2,300 W

Design, comfort

- Built-in appliance for a 60 cm wide tall cupboard
- Heating types: microwave, grill, hot air, combination cooking
- Touch control
- 5 output levels: 1,000 W, 800 W, 500 W, 300 W, 100 W
- 10 automatic programmes
- Defrost by weight / time
- Red LED Digital display
- 34l stainless steel cavity
- 31.5 cm glass turntable
- Child safety lock
- Push open door

Dimensions H x W x D

- Appliance dimensions: 38.8 x 59.5 x 47.0 cm
- Installation dimensions: 38.0 x 56.0 x 55.0 cm



Built-in compact microwave oven

5MA 27500IN

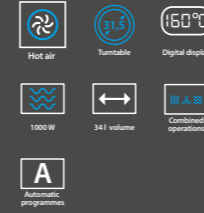
**Output, consumption**

- Voltage: 230 – 240 V
- Connected load: 2.3 kW
- 1,000 W Microwave
- Grill Power: 1,100 W
- Hot air Power: 2,300 W

Design, comfort

- Built-in microwave, stainless steel
- Heating types: microwave, grill, hot air, combination cooking
- Knob and button control
- 5 output levels: 1,000 W, 800 W, 500 W, 300 W, 100 W
- 10 automatic programmes
- Defrost by weight / time
- White LED digital display
- 34l stainless steel cavity
- 31.5 cm glass turntable
- Child safety lock
- Push open door

Dimensions H x W x D

- Appliance dimensions: 38.8 x 59.5 x 47.0 cm
- Installation dimensions: 38.0 x 56.0 x 55.0 cm



Built-in microwave

5MG 16199IN

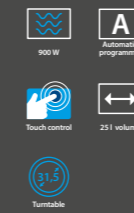
**Output, consumption**

- Voltage: 220 – 230 V
- Connected load: 2.45 kW
- 900 W Microwave
- Grill output: 1,000 W

Design, comfort

- Built-in appliance for a 60 cm wide tall cupboard
- Heating types: microwave, grill, combined microwave and grill
- Control panel made of glass
- Easy-to-use electronics
- 5 output levels: 900 W, 600 W, 360 W, 180 W, 90 W
- Programmes mode for 8 programmes
- Automatic weight adjustment for defrost programmes
- Digital display
- Digital clock with day display
- 25l stainless steel cooking chamber
- Cooking chamber lighting
- 31.5 cm glass turntable
- Child protection
- Door hinged on the left

Dimensions H x W x D

- Appliance dimensions: 38.2 x 59.4 x 40.3 cm
- Installation dimensions: 38.0 x 56.0 x 55.0 cm





HOBS

Not all heat is alike. Sometimes the temperature has to rise rapidly – boosting heat for perfect searing. Other things need time – uniform heat for gentle cooking.

Stand-alone hob, combi induction

511 94291

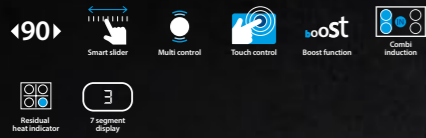
**Output, consumption**

- Voltage: 220 – 240 V
- Total connected load: 7.4 kW
- 5 induction cooking zones with booster:
- 2 cooking zones, combi induction
Ø 20.0 x 21.0 cm, 2.3 kW (3.0 kW)
- 2 cooking zones, combi induction
Ø 20.0 x 21.0 cm, 2.3 kW (3.0 kW)
- 1 cooking zone Ø 21.5 cm, 2.3 kW (3.0 kW)

Design, comfort

- Frameless
- Multi Control
- Smart Slider
- Touch Control
- 2 x combi induction
- Flexible linking – Any two cooking zones can be combined into one cooking zone
- Boost function for all induction cooking zones
- Grill function
- Electronic control in 10 power levels
- Digital display of cooking levels in white
- Residual heat display for each cooking zone
- Pot detection
- Child protection
- Timer – simultaneously adjustable for each cooking zone
- Countdown function
- Quick start function
- Recall function – Repeat the last settings
- Automatic safety switch-off
- Overflow detection
- Power management
- Flush-mounted installation possible
- Quick assembly system

Dimensions H x W x D

- Appliance dimensions: 5.2 x 88.0 x 52.0 cm
- Installation dimensions: 5.2 x 81.0 x 49.0 cm



Stand-alone hob, combi induction

511 94291

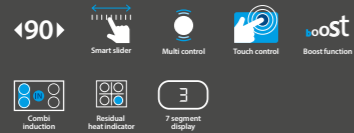
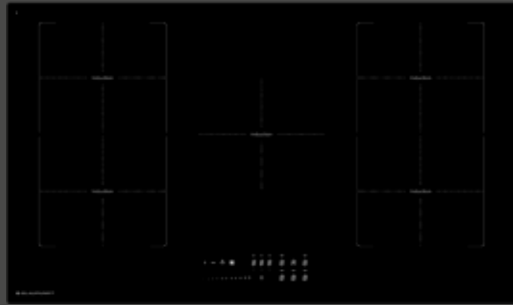
**Output, consumption**

- Voltage: 220 – 240V
- Total connected load: 7.4 kW
- 5 induction cooking zones with booster:
 - 2 cooking zones, combi induction Ø 20.0 × 21.0 cm, 2.3 kW (3.0 kW)
 - 2 cooking zones, combi induction Ø 20.0 × 21.0 cm, 2.3 kW (3.0 kW)
 - 1 cooking zone Ø 21.5 cm, 2.3 kW (3.0 kW)

Design, comfort

- Frameless
- Multi Control
- Smart Slider
- Touch Control
- 2 × combi induction
- Flexible linking – Any two cooking zones can be combined into one cooking zone
- Boost function for all induction cooking zones
- Grill function
- Electronic control in 10 power levels
- Digital display of cooking levels in white
- Residual heat display for each cooking zone
- Pot detection
- Child protection
- Timer – simultaneously adjustable for each cooking zone
- Countdown function
- Quick start function
- Recall function – Repeat the last settings
- Automatic safety switch-off
- Overflow detection
- Power management
- Flush-mounted installation possible
- Quick assembly system

Dimensions H × W × D

- Appliance dimensions: 5.2 × 88.0 × 52.0 cm
- Installation dimensions: 5.2 × 81.0 × 49.0 cm



Stand-alone hob, induction

51Z 34291

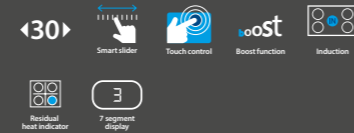
**Output, consumption**

- Voltage: 220 – 240V
- Total connected load: 3.7 kW
- 2 induction cooking zones with booster:
 - 2 cooking zones Ø 17.5 cm, 1.4 kW (2.1 kW)

Design, comfort

- Frameless
- Smart Slider
- Touch Control
- Boost function for all induction cooking zones
- Electronic control in 10 power levels
- Digital display of cooking levels
- Residual heat display for each cooking zone
- Pot detection
- Child lock
- Timer – simultaneously adjustable for each cooking zone
- Countdown function
- Quick start function
- Recall function – Repeat the last settings
- Automatic safety switch-off
- Overflow detection
- Power management
- Flush-mounted installation possible
- Quick assembly system

Dimensions H × W × D

- Appliance dimensions: 5.2 × 30.0 × 52.0 cm
- Installation dimensions: 5.2 × 27.0 × 49.0 cm

**Griddle**

5Z 99GP01

**Teppanyaki plate**

5Z 99TP01

H × W × D
40.8 × 24.0 × 5 cm incl. handle
40.8 × 24.0 × 2.1 cm without handle

Compatible with all Blaupunkt hobs.

It's every barbecue fan's dream: It may be raining, snowing or stormy outside – he can still indulge his passion inside. With the cast iron barbecue grill or the Teppanyaki grill, steaks, fish and vegetables get that familiar aroma from the open-air barbecue season.



Multi Control

MULTI CONTROL

A unique match

Here everything comes together that belongs together: Blaupunkt hobs with Multi Control  form a unique combination – together with the Multi Control extractor fan hoods. These can be easily controlled using the hob operating panel, and automatically adjust their output in line with the heat generated by the hob.

Optional extendible Multi Control function: The installation of a small receiver in the hood suffices to put your kitchen in the perfect light. This allows you to use a remote control to control the light mood and intensity.

If your kitchen is also furnished with this technology, the hood and the light system can be coupled together, thereby resulting in a perfectly harmonized look with a uniform light colour and intensity!



Receiver

BLZ 501

Remote

BLZ 502

Here you can find all the information about Multi Control.



GAS HOBS

Change the temperature at lightning speed – cooking on an open flame is direct, emotional and, thanks to the latest technology, completely safe. A Blaupunkt gas hob is an eye-catcher in the kitchen and delivers a truly professional cooking experience.



Gas hob

5GH 65BB390



<60>

Output, consumption

- Connected load, gas: 8.25 kW
- Brass Burner with 3 cooking areas:
- Left front brass burner: 4.5 kW
- Right front brass burner: 2.0 kW
- Right rear brass burner: 1.75 kW
- Voltage: 220–240 V
- Frequency: 50–60 Hz

Design, comfort

- Black Glass, Cast Iron
- Front control knob (black knob)
- Electrical spoke spark ignition controllable with one hand
- Protection against unintentional escape of gas (thermoelectric safety pilot)
- Present to LPG
- Can be converted to Natrul Gas / NG nozzle is not included in the package but can be purchased as an accessory part
- Connection cable 1.5 m

Dimensions H × W × D

- Appliance dimensions: 8.07 × 59.0 × 51.0 cm
- Cut out dimensions: 56.0 × 49.0 cm



Gas hob

5GH 65BB490



<60>

Output, consumption

- Connected load, gas: 9.25 kW
- Brass Burner with 4 cooking areas:
- Left front brass burner: 4.5 kW
- Left rear brass burner: 2.0 kW
- Right front brass burner: 1.0 kW
- Right rear brass burner: 1.75 kW
- Voltage: 220–240 V
- Frequency: 50–60 Hz

Design, comfort

- Black Glass, Cast Iron
- Front control knob (black knob)
- Electrical spoke spark ignition controllable with one hand
- Protection against unintentional escape of gas (thermoelectric safety pilot)
- Present to LPG
- Can be converted to Natrul Gas / NG nozzle is not included in the package but can be purchased as an accessory part
- Connection cable 1.5 m

Dimensions H × W × D

- Appliance dimensions: 8.07 × 59.0 × 51.0 cm
- Cut out dimensions: 56.0 × 49.0 cm



Gas hob

5GH 75BB390



<77>

Output, consumption

- Connected load, gas: 8.25 kW
- Brass Burner with 3 cooking areas:
- Left front brass burner: 4.5 kW
- Right front brass burner: 2.0 kW
- Middle rear brass burner: 1.75 kW
- Voltage: 220–240 V
- Frequency: 50–60 Hz

Design, comfort

- Black Glass, Cast Iron
- Front control knob (black knob)
- Electrical spoke spark ignition controllable with one hand
- Protection against unintentional escape of gas (thermoelectric safety pilot)
- Present to LPG
- Can be converted to Natrul Gas / NG nozzle is not included in the package but can be purchased as an accessory part
- Connection cable 1.5 m

Dimensions H × W × D

- Appliance dimensions: 8.07 × 77.0 × 51.0 cm
- Cut out dimensions: 73.0 × 49.0 cm



Gas hob

5GH 75BB490



<77>

Output, consumption

- Connected load, gas: 9.25 kW
- Brass Burner with 4 cooking areas:
- Left front brass burner: 4.5 kW
- Right front brass burner: 2.0 kW
- Middle front brass burner: 1.0 kW
- Middle rear brass burner: 1.75 kW
- Voltage: 220–240 V
- Frequency: 50–60 Hz

Design, comfort

- Black Glass, Cast Iron
- Front control knob (black knob)
- Electrical spoke spark ignition controllable with one hand
- Protection against unintentional escape of gas (thermoelectric safety pilot)
- Present to LPG
- Can be converted to Natrul Gas / NG nozzle is not included in the package but can be purchased as an accessory part
- Connection cable 1.5 m

Dimension H × W × D

- Appliance dimensions: 8.07 × 77.0 × 51.0 cm
- Cut out dimensions: 73.0 × 49.0 cm



Gas hob

5GH 85BB390



◀86▶

Output, consumption

- Connected load, gas: 10.75 kW
- Brass burner with 3 cooking areas:
- Left front brass burner: 4.5 kW
- Right front brass burner: 4.5 kW
- Middle rear brass burner: 1.75 kW
- Voltage: 220–240 V
- Frequency: 50–60 Hz

Design, comfort

- Black Glass, Cast Iron
- Front control knob (black knob)
- Electrical spoke spark ignition controllable with one hand
- Protection against unintentional escape of gas (thermoelectric safety pilot)
- Present to LPG
- Can be converted to Natrul Gas / NG nozzle is not included in the package but can be purchased as an accessory part
- Connection cable 1.5 m

Dimension H × W × D

- Appliance dimensions: 8.07 × 86.0 × 51.0 cm
- Cut out dimensions: 73.0 × 49.0 cm



Gas hob

5GH 85BB490



◀86▶

Output, consumption

- Connected load, gas: 9.25 kW
- Brass Burner with 4 cooking areas:
- Left front brass burner: 4.5 kW
- Right front brass burner: 2.0 kW
- Middle front brass burner: 1.0 kW
- Middle rear brass burner: 1.75 kW
- Voltage: 220–240 V
- Frequency: 50–60 Hz

Design, comfort

- Black Glass, Cast Iron
- Front control knob (black knob)
- Electrical spoke spark ignition controllable with one hand
- Protection against unintentional escape of gas (thermoelectric safety pilot)
- Present to LPG
- Can be converted to Natrul Gas / NG nozzle is not included in the package but can be purchased as an accessory part
- Connection cable 1.5 m

Dimension H × W × D

- Appliance dimensions: 8.07 × 86.0 × 51.0 cm
- Cut out dimensions: 73.0 × 49.0 cm



Gas hob

5GH 85BB590



◀86▶

Output, consumption

- Connected load, gas: 11.25 kW
- Brass Burner with 5 cooking areas
- Left front brass burner: 1.0 kW
- Left rear brass burner: 2.0 kW
- Right front brass burner: 2.0 kW
- Right rear brass burner: 1.75 kW
- Middle front brass burner: 4.5 kW
- Voltage: 220–240 V
- Frequency: 50–60 Hz

Design, comfort

- Black Glass, Cast Iron
- Front control knob (black knob)
- Electrical spoke spark ignition controllable with one hand
- Protection against unintentional escape of gas (thermoelectric safety pilot)
- Present to LPG
- Can be converted to Natrul Gas / NG nozzle is not included in the package but can be purchased as an accessory part
- Connection cable 1.5 m

Dimension H × W × D

- Appliance dimensions: 8.07 × 86.0 × 51.0 cm
- Cut out dimensions: 73.0 × 49.0 cm



Gas hob

5GB 62191IN New



◀60▶

Output, consumption

- Connected load, gas: 8.1 kW
- Burner with 4 cooking areas:
- 2 normal burners 1.75 kW
- 1 energy-saving burner 1.0 kW
- 1 triple burner 3.6 kW

Design, comfort

- Black glass, hardened
- Front control knob
- Electrical spoke spark ignition controllable with one hand
- Protection against unintentional escape of gas (thermoelectric safety pilot)
- Cast iron pot carrier
- Preset to natural gas (20 mbar)
- Convertible to liquid gas (not included in the scope of delivery)
- Connection cable 1 m

Dimensions H × W × D

- Appliance dimensions: 9.0 × 60.0 × 51.5 cm
- Installation dimensions: 56.0 × 49.0 cm



Gas hob

5GB 72290IN New



◀75▶

Output, consumption

- Connected load, gas: 11.1 kW
- Burner with 5 cooking areas:
- 2 normal burners 1.75 kW
- 1 energy-saving burner 1.0 kW
- 1 triple burner 3.6 kW
- 1 strong burner 3.0 kW

Design, comfort

- Black glass, hardened
- Front control knob
- Electrical spoke spark ignition controllable with one hand
- Protection against unintentional escape of gas (thermoelectric safety pilot)
- Cast iron pot carrier
- Preset to natural gas (20 mbar)
- Convertible to liquid gas (not included in the scope of delivery)
- Connection cable 1 m

Dimensions H × W × D

- Appliance dimensions: 9.0 × 75.0 × 52.0 cm
- Installation dimensions: 56.0 × 49.0 cm



HOBS WITH INTEGRATED EXTRACTOR

The modern extractor solution offers one thing above all – more freedom: A clear view, as the fumes are extracted directly where they arise. Odourless cooking and more freedom in kitchen planning.

High-quality filter systems allow nothing but fresh air to be produced, while still being powerful and noise-free. The perfect combination of heat and air in a single appliance.

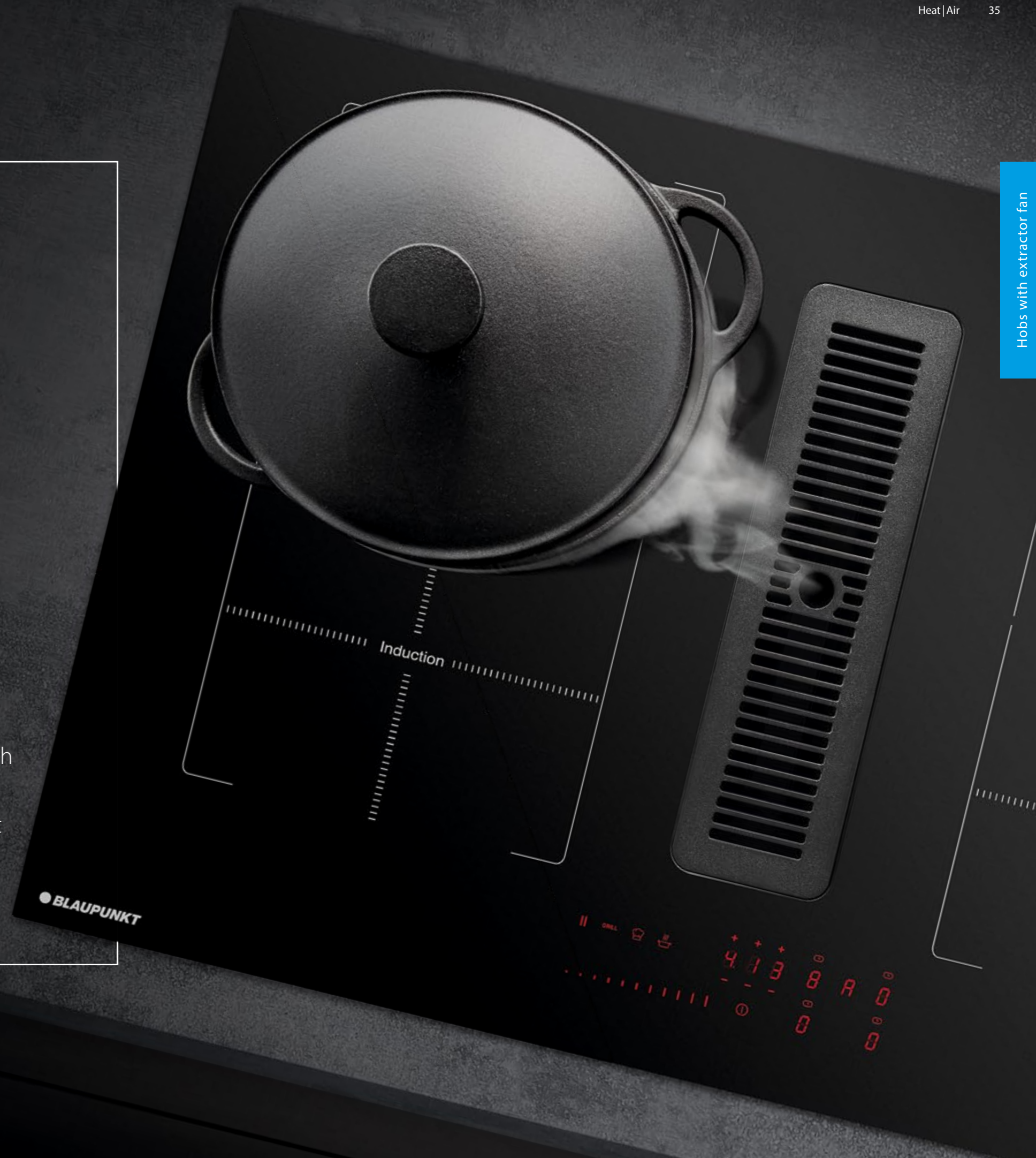

THE BEST FEATURES AT A GLANCE

New 5IX 80290 and 5IX 60290 induction hobs with integrated extractor fan.

The ventilation system is activated automatically when a cooking zone is in use

Flexible planning – surface- or flush-mounting installation possible

2 in 1 – Exhaust and circulating air in one device

Simple filter exchange and easy cleaning

Hobs with extractor fan

Simple and intuitive operation

Fan motor integrated directly into the hob

State-of-the-art technology and fast installation

Minimalist design



Here you can find all information about our hob fans.

Stand-alone hob, combi induction with integrated extractor fan

5IX 80290 New

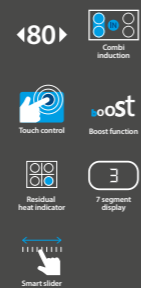
**Output, consumption – hob**

- Voltage: 220–240 V
- Total connected load: 7.4 kW
- 4 induction cooking zones with booster:
- 4 cooking zones Ø 19.0×21.0 cm, 2.1 kW (3.7 kW)

Design, comfort

- Frameless
- Multi Control
- Smart Slider
- Touch Control
- 2 × combi induction
- Flexible linking – Any two cooking zones can be combined into one cooking zone
- Boost function for all induction cooking zones
- Grill function
- Cooking Chef Mode
- Electronic control in 11 power levels
- Digital display of cooking levels in red
- Residual heat display for each cooking zone
- Pot detection
- Child protection
- Timer – simultaneously adjustable for each cooking zone
- Countdown function
- Quick start function
- Recall function – Repeat the last settings
- Automatic safety switch-off
- Overflow detection
- Power management
- Flush-mounted installation possible
- Quick assembly system

Dimensions H × W × D

- Appliance dimensions: 20.1 × 78.0 × 52.0 cm
- Installation dimensions: 19.7 × 75.0 × 50.0 cm

Output, consumption – extractor fan

- Voltage: 220–240 V
- Total connected load: 163 W
- Average power consumption: 31.2 kWh/year
- Noise min./max. Normal level/Intensive level:
- Min. 34 dB (A) Max. 69 dB (A) Max. 72 dB (A)
- Fan output max. Normal level/Intensive level:
- In extraction mode 434 m³/h / 500 m³/h
- In circulation mode 350 m³/h / 400 m³/h

Design, comfort – extractor fan

- With fan motor integrated into the hob
- Suitable for installation in a kitchenette or kitchen island
- Optional extraction or circulation mode (carbon filter required for circulation mode)
- 10-level fan output controllable via Touch Control
- 9 power levels + 1 intensive level
- Intensive level with automatic reset for extraction mode
- Automatic blower overrun
- Metal grease filter and carbon filter saturation indication by LED control lamp
- The device automatically blocks after 30 hours of operation for filter cleaning
- Powerful and quiet blower
- The ventilation system is activated automatically when a cooking zone is in use

Accessories

- Metal grease filter, dishwasher-safe

Stand-alone hob, combi induction with integrated extractor fan

5IX 60290 New

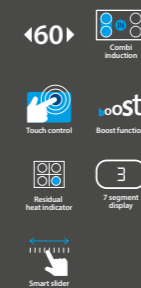
**Output, consumption – hob**

- Voltage: 220–240 V
- Total connected load: 7.4 kW
- 4 induction cooking zones with booster:
- 2 cooking zones Ø 16.0 cm, 1.4 kW (1.85 kW)
- 2 cooking zone Ø 17.5, 1.4 kW (2.1 kW)

Design, comfort

- Frameless
- Multi Control
- Smart Slider
- Touch Control
- Boost function for all induction cooking zones
- Electronic control in 11 power levels
- Digital display of cooking levels in red
- Residual heat display for each cooking zone
- Pot detection
- Child protection
- Timer – simultaneously adjustable for each cooking zone
- Countdown function
- Quick start function
- Recall function – Repeat the last settings
- Automatic safety switch-off
- Overflow detection
- Power management
- Flush-mounted installation possible
- Quick assembly system

Dimensions H × W × D

- Appliance dimensions: 20.1 × 59.0 × 52.0 cm
- Installation dimensions: 19.7 × 59.0 × 50.0 cm

Output, consumption – extractor fan

- Voltage: 220–240 V
- Total connected load: 165 W
- Average power consumption: 33.2 kWh/year
- Noise min./max. Normal level/Intensive level:
- Min. 34 dB (A) Max. 69 dB (A) Max. 72 dB (A)
- Fan output max. Normal level/Intensive level:
- In extraction mode 424 m³/h / 441 m³/h
- In circulation mode 339 m³/h / 353 m³/h

Design, comfort – extractor fan

- With fan motor integrated into the hob
- Suitable for installation in a kitchenette or kitchen island
- Optional extraction or circulation mode (carbon filter required for circulation mode)
- 10-level fan output controllable via Touch Control
- 9 power levels + 1 intensive level
- Intensive level with automatic reset for extraction mode
- Automatic blower overrun
- Metal grease filter and carbon filter saturation indication by LED control lamp
- The device automatically blocks after 30 hours of operation for filter cleaning
- Powerful and quiet blower
- The ventilation system is activated automatically when a cooking zone is in use

Accessories

- Metal grease filter, dishwasher-safe



Planning information

for 5IX 60290 / 5IX 80290

(with fan motor integrated into the hob)

The following must be considered during planning and installation:

- The fan motor is integrated directly into the hob
- Naber Compair Flow 150 air discharge, allowing for freedom in planning airflow
- Airflow can be routed in any direction
- Dishwashers, under-counter refrigerators, drawers etc. cannot be planned in the area of the exhaust air duct
- Min. cabinet width 800 mm (5IX 80290)
- Min. cabinet width 600 mm (5IX 60290)
- Min. worktop depth 600 mm (correspondingly deeper when planning in niche panelling)
- Worktop depth 600 mm (for flush-mounted planning)
- Base height min. 100 mm (depending on the duct system used)

Extraction mode

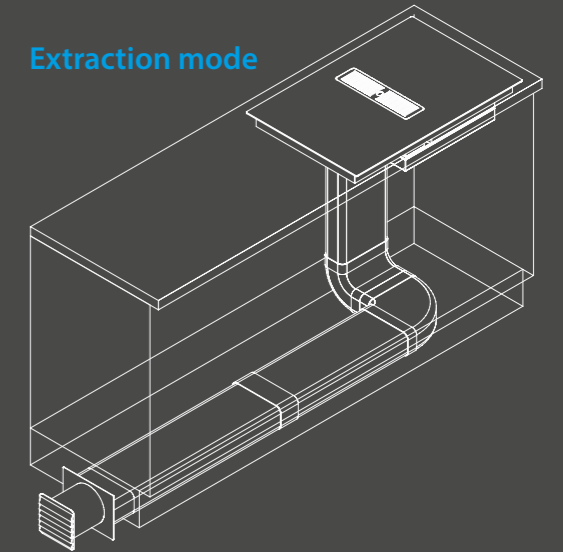

Circulation mode

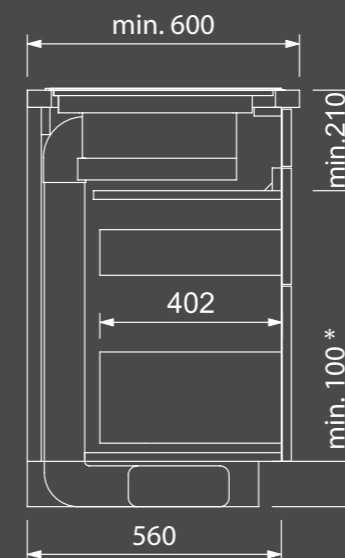
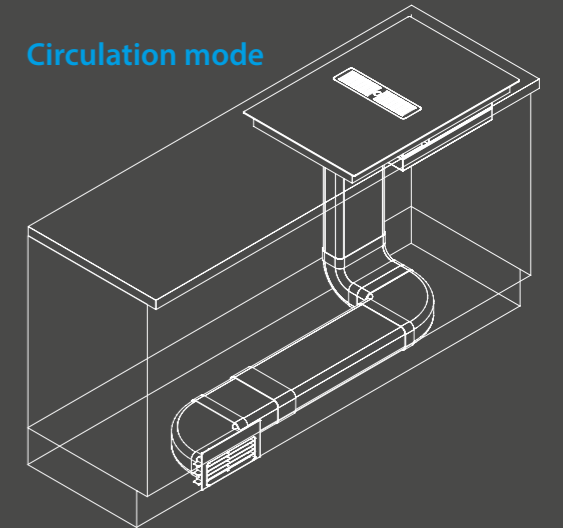

*depending on the duct system used

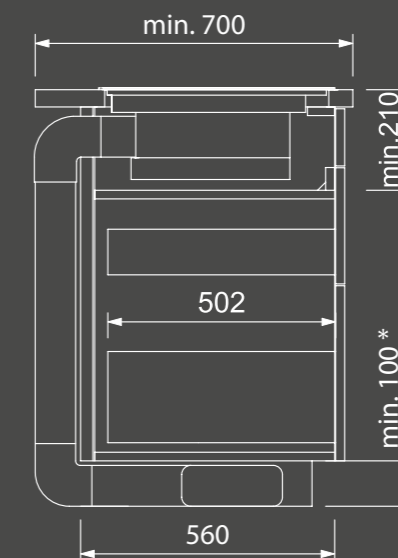

*depending on the duct system used

Using a flat ducting system to extract outside of the carcass.

EXTRACTOR FAN HOODS

Searched crispy or gently steamed:
each meal preparation leaves
traces behind in the room.
Blaupunkt extractor fan hoods provide
fresh air after each cooking experience.



Island hood

5DF 92760

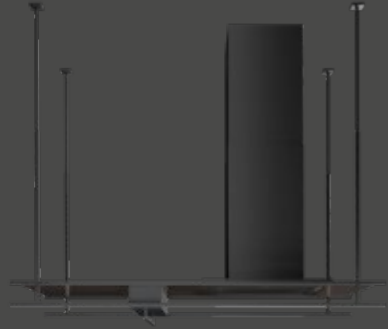
**Output, consumption**

- Voltage: 220–240 V
- Total connected load: 208.2 W
- Average power consumption: 51 kWh/year
- Noise min./max. Normal level: 48/64 dB
- Fan output max. Normal level/Intensive level:
 - In extraction mode 521 m³/h/650 m³/h
 - In circulation mode 380 m³/h/480 m³/h

Design, comfort

- Black painted stainless steel
- For ceiling installation above kitchen islands
- Optional extraction or circulation mode (an activated carbon filter required for circulation mode)
- 4-level fan power (3 power levels + 1 intensive level) controllable via remote control
- Intensive levels with automatic reset
- High, fine-tunable fan power
- Powerful and quiet blower
- Uniform, bright lighting with 2 × 4.1 W LED modules
- Illuminance: 270 lux
- Colour temperature: 4,000 K

Accessories

- Metal grease filter, dishwasher-safe

Dimensions H × W × D

- Appliance dimensions, extraction: 90.0 – 109.0 × 140.0 × 60.0 cm
- Appliance dimensions, circulation: 96.5 – 120.0 × 140.0 × 60.0 cm



Island hood

5DB 96453 New

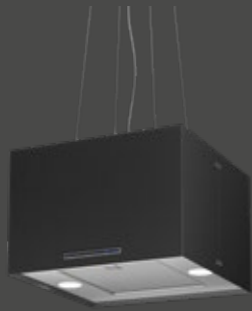
**Output, consumption**

- Voltage: 220–240 V
- Total connected load: 225.4 W
- Average power consumption: 43 kWh/year
- Noise min./max. Normal level: 48/60 dB
- Fan output max. Normal level/Intensive level:
 - In circulation mode 394 m³/h/445 m³/h

Design, comfort

- Stainless steel and black painted stainless steel
- For ceiling installation above kitchen islands
- Multi Control
- Circulation hood (an activated carbon filter required for circulation mode)
- Electronic control
- 4-level fan power (3 power levels + 1 intensive level) controllable through Multi Control
- Intensive levels with automatic reset
- Powerful and quiet blower
- Uniform, bright lighting with 2 × 2.7 W LED modules
- Optional extendible Multi Control function: LED light with adjustable brightness and colour temperature
- Colour temperature: 4,000 K preset

Accessories

- Metal grease filter, dishwasher-safe

Special accessories for extended Multi Control function (see page 25)

- BLZ 501 Receiver
- BLZ 502 Remote control

Dimensions H × W × D

- Appliance dimensions, circulation: 170.5 × 45.0 × 45.0 cm



Island hood

5IT 99450

**Output, consumption**

- Voltage: 220–240 V
- Total connected load: 196 W
- Noise max. normal level: 68 dB
- Powerful suction
- Fan output max. 734 m³/h

Design, comfort

- Stainless steel
- For ceiling installation above kitchen islands
- Extraction mode
- Soft electronic control
- 3 power levels
- Uniform, bright lighting with 4 × 1.5 W LED lamps
- 5 layers of aluminum filter

Dimensions H × W × D

- Appliance dimensions: 119.2 × 89.5 × 60.0 cm



Vertical hood

5DX 89770 New

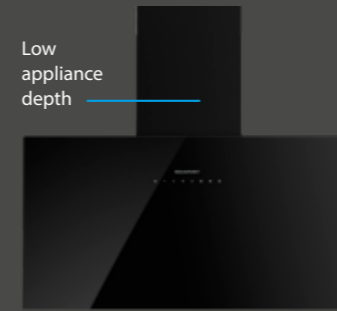
**Output, consumption**

- Voltage: 220–240 V
- Total connected load: 130.4 W
- Average power consumption: 40.4 kWh/year
- Noise min./max. Normal level: 52/67 dB
- Fan output max. Normal level/Intensive level:
 - In extraction mode max. 400 m³/h/570 m³/h
 - In circulation mode max. 120 m³/h/145 m³/h

Design, comfort

- Black painted stainless steel and black glass
- For wall installation above cooking zones
- Multi Control
- Touch Control
- Optional extraction or circulation mode (carbon filter required for circulation mode)
- Electronic control
- 4-level fan power (3 power levels + 1 intensive level) controllable through Multi Control
- Intensive levels with automatic reset
- Filter saturation display
- Powerful and quiet blower
- Uniform, bright lighting with 2 × 2.7 W LED modules
- Illuminance: 154 lux
- Optional extendible Multi Control function: LED light with adjustable brightness and colour temperature
- Colour temperature: 4,000 K preset

Accessories

- Metal grease filter, dishwasher-safe
- Incl. exhaust air shaft

Special accessories for extended Multi Control function (see page 25)

- BLZ 501 Receiver
- BLZ 502 Remote control

Dimensions H × W × D

- Appliance dimensions, extraction: 73.0 – 105.0 × 90.0 × 23.2 cm
- Appliance dimensions, circulation: 85.5.0 – 105.0 × 90.0 × 23.2 cm



Oblique hood

5DL 69654 New

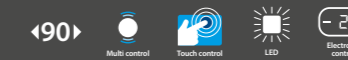
**Output, consumption**

- Voltage: 220–240 V
- Total connected load: 276 W
- Average power consumption: 46.4 kWh/year
- Noise min./max. Normal level: 52/64 dB
- Fan output max. Normal level/Intensive level:
 - In extraction mode 630 m³/h/790 m³/h
 - In circulation mode 385 m³/h/430 m³/h

Design, comfort

- Black glass screen with Dark Steel front
- With gas pressure damper
- For wall installation above hobs
- Optional extraction or circulation mode (an activated carbon filter required for circulation mode)
- Electronic control
- 4-level fan power (3 power levels + 1 intensive level) controllable through Multi Control
- Filter saturation display
- Powerful and quiet blower
- High, fine-tunable fan power
- Edge suction
- Uniform, bright lighting with 2 × 2.7 W LED lamps
- Illuminance: 154 lux
- Colour temperature: 4,000 K preset

Accessories

- Metal grease filter, dishwasher-safe
- Incl. exhaust air shaft

Special accessories for extended Multi Control function (see page 25)

- BLZ 501 Receiver
- BLZ 502 Remote control

Dimensions H × W × D

- Appliance dimensions, extraction: 71.2 – 102.2 × 90.0 × 34.0 cm
- Appliance dimensions, circulation: 83.7 – 102.2 × 90.0 × 34.0 cm



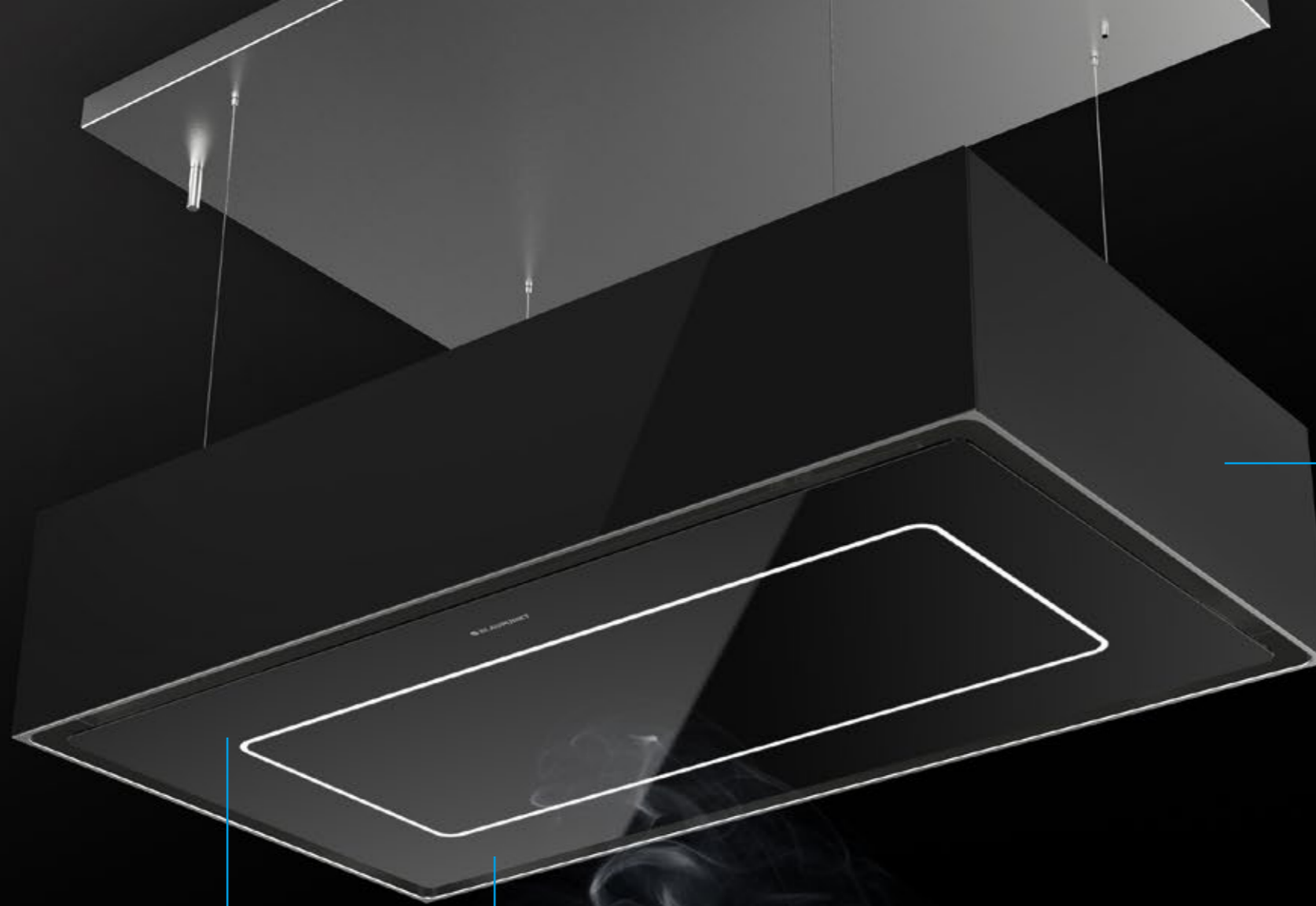

Thanks to the lift function, the hood moves down to the desired height almost noiselessly.

The hood can be raised elegantly to the ceiling when not in use, creating space above the hob and serving as a lamp to light the kitchen.

Made of glass and stainless steel, the hood stands out for its extremely clear and elegant design.

Island hood

5SL 92500 New



Output, consumption

- Voltage: 220 – 240 V
- Total connected load: 194 W
- Noise min. / max. normal level: 55 / 66 dB
- Fan output max. normal level / intensive level:
- In circulation mode 500 m³ / h / 550 m³ / h

Design, comfort

- Black Glass and Dark Steel
- For ceiling installation above kitchen islands
- Circulation mode (activated carbon filter required for circulation mode)
- Electronic control
- 4-level fan power (3 power levels + 1 intensive level) controllable through remote control
- Intensive levels with automatic reset
- Powerful and quiet blower
- Uniform, bright lighting with 1 × 16 W LED modules
- Colour temperature: 4,000 K

Accessories

- Metal grease filter, dishwasher-safe
- Remote control

Dimensions H × W × D

- Device dimensions closed: 28.0 × 108.7 × 58.7 cm
- Device dimensions extended: 128.0 × 108.7 × 58.7 cm



Oblique hood

5IL 69361

**Output, consumption**

- Voltage: 220 – 230 V
- Total connected load: 203 W
- Noise max. normal level: 72 dB
- Powerful suction
- Fan output max. 720 m³/h

Design, comfort

- Black Powder coating + Black tempered glass
- For wall installation above hobs
- Extraction mode
- Touch control & Motion sensor
- Heat auto cleaning
- 3 power levels
- Uniform, bright lighting with 2 × 1.5 W LED lamps
- Filterless Design

Dimensions H × W × D

- Appliance dimensions: 84.8 × 89.5 × 33.8 cm



Oblique hood

5IL 66361

**Output, consumption**

- Voltage: 220 – 230 V
- Total connected load: 203 W
- Noise max. normal level: 72 dB
- Powerful suction
- Fan output max. 720 m³/h

Design, comfort

- Black Powder coating + Black tempered glass
- For wall installation above hobs
- Extraction mode
- Touch control & Motion sensor
- Heat auto cleaning
- 3 power levels
- Uniform, bright lighting with 2 × 1.5 W LED lamps
- Filterless Design

Dimensions H × W × D

- Appliance dimensions: 84.8 × 59.5 × 33.8 cm



Oblique hood

5IL 66261

**Output, consumption**

- Voltage: 220 – 230 V
- Total connected load: 203 W
- Noise max. normal level: 72 dB
- Powerful suction
- Fan output max. 720 m³/h

Design, comfort

- Black Powder coating + Black tempered glass
- For wall installation above hobs
- Extraction mode
- Touch control & Motion sensor
- Heat auto cleaning
- 3 power levels
- Uniform, bright lighting with 2 × 1.5 W LED lamps
- Filterless Design

Dimensions H × W × D

- Appliance dimensions: 84.8 × 59.5 × 34.5 cm



Wall hood

5IS 69860 New

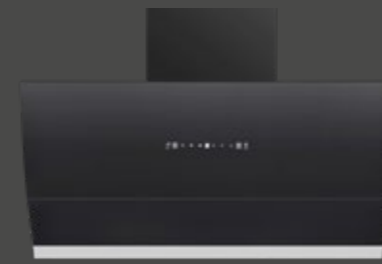
**Output, consumption**

- Voltage: 220 – 230 V
- Total connected load: 256 W
- Noise max. normal level: 72 dB
- Fan output max. 900 m³/h

Design, comfort

- Black Powder coating + Curve glass panel
- For wall installation above hobs
- Extraction mode
- Touch control & Motion sensor
- Heat auto cleaning
- 3 power levels
- 2 × 1.5 W LED lamps
- Filterless Design

Dimensions H × W × D

- Appliance dimensions: 84.9 × 89.8 × 34.0 cm



Wall hood

5IS 66860 New

**Output, consumption**

- Voltage: 220 – 230 V
- Total connected load: 256 W
- Noise max. normal level: 72 dB
- Fan output max. 900 m³/h

Design, comfort

- Black Powder coating + Curve glass panel
- For wall installation above hobs
- Extraction mode
- Touch control & Motion sensor
- Heat auto cleaning
- 3 power levels
- 2 × 1.5 W LED lamps
- Filterless Design

Dimensions H × W × D

- Appliance dimensions: 84.9 × 59.8 × 34.0 cm



Wall hood

5DS 69770 New

**Output, consumption**

- Voltage: 220 – 240 V
- Total connected load: 274 W
- Average power consumption: 43 kWh/year
- Noise min./max. Normal level: 52/65 dB
- Fan output max. Normal level/Intensive level:
- In extraction mode max. 580 m³/h/700 m³/h
- In circulation mode max. 450 m³/h/500 m³/h

Design, comfort

- Black painted stainless steel and black glass screen
- For wall installation above cooking zones
- Smart Slider
- Touch Control
- Optional extraction or circulation mode (an activated carbon filter required for circulation mode)
- Electronic control
- 4-level fan power (3 power levels + 1 intensive level) controllable via Smart Slider with LED display
- Intensive levels with automatic reset
- Powerful and quiet blower
- Uniform, bright lighting with 2 × 2 W LED lamps
- Illuminance: 180 lux
- Colour temperature: 4,000 K

Accessories

- Metal grease filter, dishwasher-safe
- Incl. exhaust air shaft

Dimensions H × W × D

- Appliance dimensions, extraction: 79.0 – 106.0 × 90.0 × 45.0 cm
- Appliance dimensions, circulation: 79.0 – 106.0 × 90.0 × 45.0 cm



Wall hood

5IH 69860 New

**Output, consumption**

- Voltage: 220 – 240 V
- Total connected load: 232 W
- Noise max. normal level: 72 dB
- Fan output max. 900 m³/h

Design, comfort

- Black Powder coating + glass panel
- For wall installation above hobs
- Extraction mode
- Touch control
- Heat auto cleaning
- 3 power levels
- 2 × 1.5 W LED lamps
- Filterless Design

Dimensions H × W × D

- Appliance dimensions: 58.8 × 89.6 × 34.0 cm



Wall hood

5IH 66860 New

**Output, consumption**

- Voltage: 220 – 240 V
- Total connected load: 232 W
- Noise max. normal level: 72 dB
- Fan output max. 900 m³/h

Design, comfort

- Black Powder coating + glass panel
- For wall installation above hobs
- Extraction mode
- Touch control
- Heat auto cleaning
- 3 power levels
- 2 × 1.5 W LED lamps
- Filterless Design

Dimensions H × W × D

- Appliance dimensions: 58.8 × 59.6 × 34.0 cm



Wall hood

5IS 69960 New

**Output, consumption**

- Voltage: 220 – 240 V
- Total connected load: 232 W
- Noise max. normal level: 72 dB
- Fan output max. 700 m³/h

Design, comfort

- Black Powder coating + glass panel
- For wall installation above hobs
- Extraction mode
- Touch control
- Heat auto cleaning
- 3 power levels
- 2 × 1.5 W LED lamps
- Filterless Design

Dimensions H × W × D

- Appliance dimensions: 58.8 × 89.6 × 34.0 cm



Wall hood

5IS 68960 New

**Output, consumption**

- Voltage: 220 – 240 V
- Total connected load: 232 W
- Noise max. normal level: 72 dB
- Fan output max. 700 m³/h

Design, comfort

- Black Powder coating + glass panel
- For wall installation above hobs
- Extraction mode
- Touch control
- Heat auto cleaning
- 3 power levels
- 2 × 1.5 W LED lamps
- Filterless Design

Dimensions H × W × D

- Appliance dimensions: 58.8 × 74.6 × 34.0 cm



Wall hood

5IS 66960 New

**Output, consumption**

- Voltage: 220 – 240 V
- Total connected load: 232 W
- Noise max. normal level: 72 dB
- Fan output max. 700 m³/h

Design, comfort

- Black Powder coating + glass panel
- For wall installation above hobs
- Extraction mode
- Touch control
- Heat auto cleaning
- 3 power levels
- 2 × 1.5 W LED lamps
- Filterless Design

Dimensions H × W × D

- Appliance dimensions: 58.8 × 59.6 × 34.0 cm



Flat hood

5DA 39452 New

**Output, consumption**

- Voltage: 220 – 240 V
- Total connected load: 76 W
- Average power consumption: 48.3 kWh / year
- Noise min. / max. Normal level: 50 / 63 dB
- Fan output max. Normal level / Intensive level:
 - In extraction mode 266 / 412 m³ / h
 - In circulation mode 166 / 353 m³ / h

Design, comfort

- Optional extraction or circulation mode (starter set required for circulation mode)
- For wall-mounted cabinet 90 cm
- Energy-saving operation thanks to efficient BLDC technology
- High, fine-tunable fan power through electronic control
- 4-level fan power (3 power levels + 1 intensive level), controllable via short-stroke keys
- Intensive levels with automatic reset
- Powerful and quiet blower / Eco Engine
- Uniform, bright lighting with 3 × 1.5 W LED lamps
- Illuminance: 355 lux
- Colour temperature: 3,500 K

Accessories

- Metal grease filter, dishwasher-safe

Dimensions H × W × D

- Appliance dimensions, extraction: 20.3 × 89.8 × 29.0 cm
- Appliance dimensions, circulation: 20.3 × 89.8 × 29.0 cm



Flat hood

5DA 36258 New

**Output, consumption**

- Voltage: 220 – 240 V
- Total connected load: 118 W
- Average power consumption: 38.6 kWh / year
- Noise min. / max. Normal level: 54 / 67 dB
- Fan power:
 - In extraction mode max. 340 m³ / h
 - In circulation mode max. 140 m³ / h

Design, comfort

- Optional extraction or circulation mode (an activated carbon filter required for circulation mode)
- For wall-mounted cabinet 60 cm
- Telescopic extension without panel
- Panel from original light strip from kitchen furniture manufacturer
- 3-level fan power controllable via slide switch
- Automatic switch-on and switch-off by pressing the moving filter surface
- Uniform, bright lighting with 2 × 4 W LED lamps
- Illuminance: 130 lux
- Colour temperature: 3,000 K

Accessories

- Metal grease filter, dishwasher-safe

Dimensions H × W × D

- Appliance dimensions: 17.5 × 59.8 × 26.0 cm
- Installation dimensions: 13.5 × 49.7 × 22.7 cm



Ceiling fan

5DD 72555

**Output, consumption**

- Voltage: 220 – 240 V
- Total connected load: 150.4 W
- Average power consumption: 38.3 kWh / year
- Noise min. / max. Normal level: 40 / 65 dB
- Fan output max. Normal level / Intensive level:
 - In extraction mode 490 m³ / h / 700 m³ / h
 - In circulation mode 300 m³ / h / 400 m³ / h

Design, comfort

- Stainless steel
- For ceiling installation above kitchen islands
- Multi Control
- Optional extraction or circulation mode (carbon filter required for circulation mode)
- Electronic control
- 4-level fan power (3 power levels + 1 intensive level) controllable through Multi Control
- Intensive levels with automatic reset
- Filter saturation display
- Powerful and quiet blower
- Uniform, bright lighting with 2 × 2.7 W LED modules
- Optional extendible Multi Control function: LED light with adjustable brightness and colour temperature
- Illuminance: 111 lux
- Colour temperature: 4,000 K preset

Accessories

- Metal grease filter, dishwasher-safe
- Remote control

Special accessories for extended**Multi Control function (see page 25)**

- BLZ 501 Receiver
- BLZ 502 Remote control

Dimensions H × W × D

- Appliance dimensions: max. 19.2 × 90.0 × 49.9 cm



Ceiling fan

5DD 72556

**Output, consumption**

- Voltage: 220 – 240 V
- Total connected load: 98 W
- Noise min. / max. Normal level: 55 / 68 dB
- Fan output max. Normal level / Intensive level:
 - In circulation mode 480 m³ / h / 550 m³ / h

Design, comfort

- Black painted stainless steel and black glass
- For ceiling installation above kitchen islands
- Multi Control
- Circulation mode (carbon filter is required for circulation mode)
- Electronic control
- 4-level fan power (3 power levels + 1 intensive level) controllable through Multi Control
- Intensive levels with automatic reset
- Powerful and quiet blower
- Uniform, bright lighting with 2 × 4 W LED modules
- Optional extendible Multi Control function: LED light with adjustable brightness and colour temperature
- Colour temperature: 4,000 K preset

Accessories

- Metal grease filter, dishwasher-safe
- Remote control

Special accessories for extended**Multi Control function (see page 25)**

- BLZ 501 Receiver
- BLZ 502 Remote control

Dimensions H × W × D

- Appliance dimensions: 16.1 × 90.0 × 55.0 cm





DISHWASHER

First the pleasure, then the work? Blaupunkt dishwashers take over the work for you, so you can keep having fun when the feast is over. Different installation heights and a wide, variable storage space: the Blaupunkt range has the right helper for every space need.

Built-in dishwasher, fully integrated

5VF 6X00EBE New

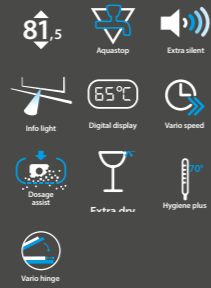
**Output, consumption**

- Capacity: 13 standard place settings
- Energy / water: 84 kWh / 9.5 l
- Noise: 44 dB (A) re 1 pW
- Connection loads: 220 – 240 V / 2.4 kW

Features

- 6 programmes: Intensive 70 °C, Auto 45 °C – 65 °C, Eco 50 °C, Glass 40 °C, 1 h 65 °C, Pre-rinse
- Machine cleaning programme
- 5 cleaning temperatures
- Hygiene Plus
- Vario Speed Plus
- Regeneration electronics / Immersion heater with integrated pump system (BLDC)
- Dosing assistant
- Aqua sensor / load sensor
- Automatic cleaning / glass protection technology
- Alternating rinse technology
- Heat exchanger
- Eco drying
- Acoustic program finish signal
- Aquastop with warranty
- Info Light
- Vario hinge

Design, comfort

- Fully integrable behind kitchen cabinet door
- Control panel on top of inside door
- Electrical time pre-selection: 1 – 24 hours / remaining time display
- Electrical refill display for salt / rinse agent
- Digital display
- Programme status display (LED)
- Self-cleaning screen with triple shaft filter system
- Cup racks in upper basket (2 ×)
- XXL dish baskets
- Variable cutlery basket in lower basket
- Rack stopper to prevent the lower basket from rolling over
- Height-adjustable upper basket with Rackmatic (3-level)
- Folding spine rows in lower basket (2 ×)
- Stainless steel interior

Dimensions H × W × D

- Appliance dimensions: 81.5 × 59.8 × 55.0 cm
- Recess dimensions: 81.5 – 87.5 × 60.0 × 55.0 cm



Built-in dishwasher, fully integrated

5VF 5X00EWE New

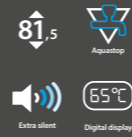
**Output, consumption**

- Capacity: 14 standard place settings
- Energy / water: 95 kWh / 12 l
- Noise: 46 dB (A) re 1 pW
- Connection loads: 220 – 240 V / 1.9 kW

Features

- 6 programmes: Intensive 65 °C, Mix 55 °C, Eco 50 °C, Quick 45 °C, Disinfect 65 °C, Soak
- Half load
- Active dry
- Immersion heater
- Automatic cleaning / glass protection technology
- Heat exchanger
- Acoustic program finish signal
- Aquastop
- Auto open door

Design, comfort

- Fully integrable behind kitchen cabinet door
- Control panel on top of inside door
- Electrical time pre-selection: 1 – 12 hours
- Electrical refill display for salt / rinse agent
- Digital display
- Programme status display (LED)
- Cup rack in upper basket
- Cutlery basket in lower basket
- Height-adjustable upper basket
- Stainless steel interior

Dimensions H × W × D

- Appliance dimensions: 82.0 – 90.0 × 59.8 × 55.5 cm
- Recess dimensions: 82.0 – 90.0 × 60.0 × 56.0 cm



Built-in dishwasher, semi integrated

5VI 311IN

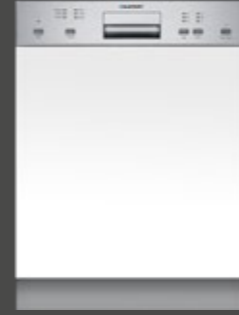
**Output, consumption**

- Capacity: 12 standard place settings
- Energy / water: 71 kWh / 10.5 l
- Noise: 49 dB (A) re 1 pW
- Connected load: 220 – 240 V / 2,1 kW

Features, comfort

- 6 programs: Intensive, Heavy, Eco, Glass, 90 min., Rapid
- Type of control: Electronic Control
- Type of display: light
- Power of heat element (230 V): 1,800 W
- Timer pre-setting 3h / 6h / 9h
- Push button functions: On / Off Button, Program Button, Delay Button, Half load, start / pause
- Functions of Indicator: Rinse Aid, end of the program, Delay time, Half load functions, program, on / off
- Type of heating element: Hidden
- Filter type: Main filter / Coarse filter / Fine filter
- Filter material: Plastic + stainless steel
- Tub material: Stainless steel
- Aquastop
- Cutlery basket in lower basket

Dimensions H × W × D

- Appliance dimensions: 81.5 × 59.8 × 57.0 cm
- Recess dimensions: 81.5 × 60.0 × 57.0 cm



Freestanding dishwasher

5VS 401IN

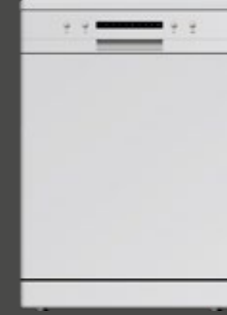
**Output, consumption**

- Capacity: 12 standard place settings
- Energy / water: 91 kWh / 11 l
- Noise: 49 dB (A) re 1 pW
- Connection loads: 220 – 240 V / 2.1 kW

Features, comfort

- 6 programs: Universal 55 °C, Intensive 65 °C, Glass 50 °C, Eco 45 °C, 90Min 60 °C, Soak
- Type of control: Electronic Control
- Type of display: light
- Power of heat element (230 V): 1,800 W
- Push button functions: On / Off Button, Program Button, Half load, start / pause
- Audible programme end signal
- Multiple water protection
- Functions of Indicator: Rinse Aid, Half load functions, program, on / off
- Type of heating element: Hidden
- Filter type: 3-fold wave filter system
- Filter material: Plastic + stainless steel
- Tub material: Stainless steel
- Cup tray in upper basket
- Folding spine rows in the lower basket
- Adjustable unloaded system upper basket
- Cutlery basket in lower basket

Dimensions H × W × D

- Appliance dimensions: 84.5 × 59.8 × 60.0 cm



REFRIGERATIONS

The various cooling zones in Blaupunkt refrigerations and freezers create the right temperature for all chilled items. Perfectly kept food retains its freshness for a long time, thanks to different temperature zones and electronic control.



Built-in freezer

5FG 288FE0 New

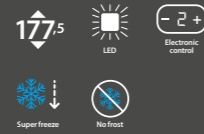
**Output, consumption**

- Energy consumption: 231 kWh / year
- Energy consumption: 0.63 kWh / 24 h
- Total capacity: 197 l
- Noise: 40 dB (A) re 1 pW
- Climate class: SN-T
- Connection loads: 220 – 240 V / 90 W

Features, comfort

- Fully integrated installation
- Easy-to-clean, bright interior
- LED interior lighting in freezer compartment
- Electronic temperature control with LED reading

****** – Freezer compartment -18°C and lower**

- NoFrost – never defrost again!
- 6 frozen produce drawers
- 2 freezer compartments with flap
- Capacity 197 l
- Freezing capacity: 11.5 kg in 24 hours
- Storage time in case of malfunction: 6 hours
- Super freezing

Technical data and dimensions H × W × D

- Flat hinge
- Door hinged on right, changeable
- Appliance dimensions: 177.0 × 54.0 × 54.5 cm
- Recess dimensions: 177.5 × 56.0 × 55.0 cm



Built-in refrigeration

5CL 288FE0 New

**Output, consumption**

- Energy consumption: 112 kWh / year
- Energy consumption: 0.306 kWh / 24 h
- Total capacity: 294 l
- Noise: 39 dB (A) re 1 pW
- Climate class: SN-ST
- Connection loads: 220 – 240 V / 90 W

Features, comfort

- Fully integrated installation
- Fully automatic defrost inside the fridge
- Electronic temperature control with LED reading
- Easy-to-clean, bright interior
- LED interior lighting in refrigeration compartment

Refrigeration compartment

- Refrigeration: Capacity 294 l
- Super cooling
- 5 shelves made of safety glass, 4 of which are height-adjustable
- 5 full-width door shelves, 1 height-adjustable
- Transparent Vario tray for fruit and vegetables, covered by a safety glass panel.
- Bottle rack
- Egg tray

Technical data and dimensions H × W × D

- Flat hinge
- Door hinged on right, changeable
- Appliance dimensions: 177.0 × 54.0 × 54.5 cm
- Recess dimensions: 177.5 × 56.0 × 55.0 cm



Built-in refrigeration / freezer combination

5CR 286FE0 New

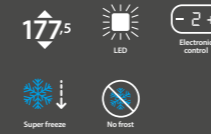
**Output, consumption**

- Energy consumption: 234 kWh / year
- Energy consumption: 0.641 kWh / 24 h
- Total capacity: 260 l
- Noise: 35 dB (A) re 1 pW
- Climate class: SN-ST
- Connection loads: 220 – 240 V / 90 W

Features, comfort

- Fully integrated installation
- Fully automatic defrost inside the fridge
- Easy-to-clean, bright interior
- LED interior lighting in refrigeration compartment
- Electronic temperature control with precise digital reading
- Super freezing with automatic deactivation

Refrigeration compartment

- Refrigeration: Capacity 184 l
- 4 shelves made of safety glass, 3 of which are height-adjustable
- Transparent Vario tray for fruit and vegetables, covered by a safety glass panel
- 3 full-width door shelves
- Egg tray

****** – Freezer compartment -18°C and lower**

- NoFrost – never defrost again!
- 3 frozen produce drawers
- Capacity 76 l
- Freezing capacity: 4 kg in 24 hours
- Storage time in case of malfunction: 10 hours
- Super freezing
- Frozen produce calendar

Technical data and dimensions H × W × D

- Flat hinge
- Door hinged on right, changeable
- Appliance dimensions: 177.2 × 54.1 × 54.8 cm
- Recess dimensions: 177.5 × 56.0 × 55.0 cm



Built-in refrigeration / freezer combination

5CC 287FE0 New

**Output, consumption**

- Energy consumption: 216 kWh / year
- Energy consumption: 0.591 kWh / 24 h
- Total capacity: 270 l
- Noise: 35 dB (A) re 1 pW
- Climate class: SN-ST
- Connection loads: 220 – 240 V / 90 W

Features, comfort

- Fully integrated installation
- Fully automatic defrost inside the fridge
- Easy-to-clean, bright interior
- LED interior lighting in refrigeration compartment
- Electronic temperature control with precise digital reading

Refrigeration compartment

- Refrigeration: Capacity 200 l
- 5 shelves made of safety glass, 4 of which are height-adjustable
- Transparent Vario tray for fruit and vegetables, covered by a safety glass panel
- 4 full-width door shelves
- Egg tray

****** – Freezer compartment -18°C and lower**

- 2 frozen produce drawers
- Capacity 70 l
- Low Frost
- Vario Zone
- Fresh Sense
- Big Box
- Freezing capacity: 3.2 kg in 24 hours
- Storage time in case of malfunction: 12 hours
- Super freezing
- Frozen produce calendar

Technical data and dimensions H × W × D

- Flat hinge
- Door hinged on right, changeable
- Appliance dimensions: 177.2 × 54.1 × 54.8 cm
- Recess dimensions: 177.5 × 56.0 × 55.0 cm



Built-in refrigeration / freezer combination

5CR 288FE0 New



177,5



Output, consumption

- Energy consumption: 218 kWh / year
- Energy consumption: 0.597 kWh / 24 h
- Total capacity: 243 l
- Noise: 41 dB (A) re 1 pW
- Climate class: N-T
- Connection loads: 220 – 240 V / 90 W

Features, comfort

- Fully integrated installation
- Fully automatic defrost inside the fridge
- Easy-to-clean, bright interior
- LED interior lighting in refrigeration compartment
- Electronic temperature control with precise digital reading

Refrigeration compartment

- Refrigeration: Capacity 180 l
- 4 shelves made of safety glass, 3 of which are height-adjustable
- Transparent Vario tray for fruit and vegetables, covered by a safety glass panel
- 4 full-width door shelves
- Bottle rack
- Egg tray

**** – Freezer compartment -18°C and lower

- 3 frozen produce drawers
- Capacity 63 l
- No Frost
- Freezing capacity: 3.3 kg in 24 hours
- Storage time in case of malfunction: 8 hours
- Frozen produce calendar

Technical data and dimensions H x W x D

- Drag hinge
- Door hinged on right, changeable
- Appliance dimensions: 177.0 x 54.0 x 54.5 cm
- Recess dimensions: 177.6 x 56.0 x 55.0 cm



Built-in refrigeration / freezer combination

5CB 288FE1 New



177,5



Output, consumption

- Energy consumption: 217 kWh / year
- Energy consumption: 0.594 kWh / 24 h
- Total capacity: 251 l
- Noise: 38 dB (A) re 1 pW
- Climate class: N-ST
- Connection loads: 220 – 240 V / 90 W

Features, comfort

- Fully integrated installation
- Fully automatic defrost inside the fridge
- Easy-to-clean, bright interior
- LED interior lighting in refrigeration compartment
- Electronic temperature control with precise digital reading

Refrigeration compartment

- Refrigeration: Capacity 181 l
- 4 shelves made of safety glass, 3 of which are height-adjustable
- Transparent Vario tray for fruit and vegetables, covered by a safety glass panel
- 4 full-width door shelves
- Bottle rack
- Egg tray

**** – Freezer compartment -18°C and lower

- 3 frozen produce drawers
- Capacity 70 l
- Low Frost
- Freezing capacity: 3.3 kg in 24 hours
- Storage time in case of malfunction: 12.5 hours
- Frozen produce calendar

Technical data and dimensions H x W x D

- Drag hinge
- Door hinged on right, changeable
- Appliance dimensions: 177.0 x 54.0 x 54.5 cm
- Recess dimensions: 177.6 x 56.0 x 55.0 cm



Built-in refrigeration / freezer combination

5CB 281FF0



177,5



Output, consumption

- Energy consumption: 217 kWh / year
- Energy consumption: 0.594 kWh / 24 h
- Total capacity: 249 l
- Noise: 39 dB (A) re 1 pW
- Climate class: N-ST
- Connection loads: 220 – 240 V / 115 W

Features, comfort

- Fully integrated installation
- Fully automatic defrost inside the fridge
- Easy-to-clean, bright interior
- LED interior lighting in refrigeration compartment

Refrigeration compartment

- Refrigeration: Capacity 179 l
- 5 shelves made of safety glass, 4 of which are height-adjustable
- Transparent Vario tray for fruit and vegetables, covered by a safety glass panel
- 3 full-width door shelves
- Egg tray

**** – Freezer compartment -18°C and lower

- 3 frozen produce drawers
- Capacity 70 l
- Freezing capacity: 3.2 kg in 24 hours
- Storage time in case of malfunction: 10 hours
- Super freezing
- Frozen produce calendar

Technical data and dimensions H x W x D

- Drag hinge
- Door hinged on right, changeable
- Appliance dimensions: 176.5 x 54.0 x 54.0 cm
- Recess dimensions: 177.2 – 177.6 x 56.0 x 55.0 cm



Undercounter refrigeration

5CP 210FF0 New



82



Output, consumption

- Energy consumption: 180 kWh / year
- Energy consumption: 0.493 kWh / 24 h
- Total capacity: 123 l
- Noise: 38 dB (A) re 1 pW
- Climate class: SN-ST
- Connection loads: 220 – 240 V / 90 W

Features, comfort

- Suitable for undercounter installation
- Fully automatic defrost inside the fridge
- Easy-to-clean, bright interior
- LED interior lighting
- Electronic temperature control
- Ventilation in the base area, no section in the worktop

Refrigeration compartment

- Refrigeration: Capacity 108 l
- 2 shelves made of safety glass, 1 of which are height-adjustable
- Transparent Vario tray for fruit and vegetables, covered by a safety glass panel
- 1 large door shelf, 2 small door shelves
- Bottle holder in extra deep door shelf

**** – Freezer compartment -18°C and lower

- 1 freezer compartment with flap
- Capacity 15 l
- Freezing capacity: 3.4 kg in 24 hours
- Storage time in case of malfunction: 8 hours

Technical data and dimensions H x W x D

- Flat hinge
- Height-adjustable front feet
- Door hinged on right, changeable
- Appliance dimensions: 82.0 x 59.8 x 54.8 cm
- Recess dimensions: 82.0 x 60.0 x 55.0 cm



Undercounter refrigeration

5CN 210FF0 New



82



Output, consumption

- Energy consumption: 114 kWh / year
- Energy consumption: 0.312 kWh / 24 h
- Total capacity: 137 l
- Noise: 38 dB (A) re 1 pW
- Climate class: SN-ST
- Connection loads: 220 – 240 V / 90 W

Features, comfort

- Suitable for undercounter installation
- Fully automatic defrost inside the fridge
- Easy-to-clean, bright interior
- LED interior lighting
- Transparent Vario tray for fruit and vegetables, covered by a safety glass panel
- Electronic temperature control
- Ventilation in the base area, no section in the worktop
- 3 shelves made of safety glass, 2 of which are height-adjustable
- 1 large door shelf, 2 small door shelves
- Bottle holder in extra deep door shelf
- Egg tray

Technical data and dimensions H x W x D

- Flat hinge
- Height-adjustable front feet
- Door hinged on right, changeable
- Appliance dimensions: 82.0 x 59.8 x 54.8 cm
- Recess dimensions: 82.0 x 60.0 x 55.0 cm



FREESTANDING REFRIGERATIONS

Freestanding refrigeration / freezer combination

5SB 891SE0 New



Output, consumption

- Energy consumption: 306 kWh/year
- Energy consumption: 0.838 kWh/24 h
- Total capacity: 513 l
- Noise: 39 dB (A) re 1 pW
- Climate class: SN-ST
- Connection loads: 220–240 V / 150 W

Features, comfort

- Freestanding side-by-side refrigeration / freezer combination
- Stainless steel look
- Rod handle
- Separate temperature regulation for refrigeration and freezer chamber
- Fully automatic defrost inside the fridge
- Easy-to-clean, bright interior
- LED interior lighting in refrigeration compartment
- Electronic temperature control with LED reading
- Water and ice dispenser + ice crusher
- External fixed water supply including 5-metre connecting hose and 3/4" water connection adapter

Refrigeration compartment

- Refrigeration: Capacity 344 l
- 4 shelves made of safety glass, 2 of which are height-adjustable
- 2 transparent Vario trays for fruit and vegetables
- 5 full-width door shelves
- Egg tray

**** – Freezer compartment -18°C and lower

- 4 shelves made of safety glass, 1 height-adjustable
- 2 frozen produce drawers
- 1 full-width door shelf
- Capacity 169 l
- NoFrost
- Freezing capacity: 12 kg in 24 hours
- Storage time in case of malfunction: 6 hours
- Super freezing with automatic freeze
- Automatic ice cube maker

Technical data and dimensions H x W x D

- Appliance dimensions: 177.0 x 90.0 x 66.0 cm



BUILT-IN WINE COOLER

Made for enjoyment

Built-in wine cooler

5WK 610FF0 New



Output, consumption

- Energy consumption: 140 kWh / year
- Energy consumption: 0.383 kWh / 24 h
- Total capacity: 83 l
- Noise: 40 dB (A) re 1 pW
- Climate class: N
- Connection loads: 220 – 240 V / 90 W

Features, comfort

- Black glass front
- Handle-free opening with push-to-open (electronic)
- Touch Control
- White LED lighting
- 3 solid wood shelves
- 36-bottle capacity
- Upper part: 24 bottles (75 cl)
- Lower part: 12 bottles (75 cl)
- 2 temperature zones for sparkling, white, rosé and red wines 5° – 12°C / 12° – 20°C
- Alarm when door is open
- Optical and acoustic temperature alarm
- Electronic temperature control with precise digital reading
- UV protection
- Demo mode
- Anti-vibration system
- Automatic defrosting
- Winter system

Technical data and dimensions H x W x D

- Flat hinge
- Door hinged on right
5WK 610FF0R
- Door hinged on left
5WK 610FF0L
- Appliance dimensions: 58.9 x 59.0 x 56.0 cm
- Recess dimensions: 59.1 x 55.0 x 55.0 cm



UNDERCOUNTER WINE COOLER

The perfect climate for fine wines



Undercounter wine cooler

5WK 820FF0 New



Output, consumption

- Energy consumption: 156 kWh/year
- Energy consumption: 0.427 kWh/24 h
- Total capacity: 132 l
- Noise: 39 dB (A) re 1 pW
- Climate class: N
- Connection loads: 220–240 V/80 W

Features, comfort

- Black glass front
- Handle-free opening with push-to-open (electronic)
- Touch Control
- White LED lighting
- 5 solid wood shelves
- 53-bottle capacity
- Upper part: 16 bottles (75 cl)
- Lower part: 37 bottles (75 cl)
- 2 temperature zones for sparkling, white, rosé and red wines 5°–12°C/12°–20°C
- Alarm when door is open
- Optical and acoustic temperature alarm
- Electronic temperature control with precise digital reading
- UV protection
- Demo mode
- Anti-vibration system
- Automatic defrosting
- Winter system

Technical data and dimensions H × W × D

- Flat hinge
- Door hinged on right
5WK 820FFOR
- Door hinged on left
5WK 820FFOL
- Appliance dimensions: 82.0–89.0 × 59.5 × 57.4 cm
- Recess dimensions: 82.5–89.5 × 60.0 × 55.5 cm



Freestanding wine cooler

5WK 750 SL New

**Output, consumption**

- Energy consumption: 152 kWh / year
- Energy consumption: 0.527 kWh / 24 h
- Total capacity: 193 l
- Noise: 41 dB (A) re 1 pW
- Climate class: SN-ST
- Connection loads: 220–240 V / 80 W

Features, comfort

- Free standing wine cooler
- Black body & stainless steel door frame
- Touch Control
- White LED lighting
- 7 solid wood shelves
- 75-bottle capacity
- Upper part: 33 bottles (75 cl)
- Lower part: 42 bottles (75 cl)
- 2 temperature zones for sparkling, white, rosé and red wines
- Adjustable temperature ranges of use:
Upper part:/ Lower part: 5°C–20°C
- Alarm when door is open
- Optical and acoustic temperature alarm
- Electronic temperature control with precise digital reading
- UV protection
- 2-layers tempered glass with lock
- Anti-vibration system
- 2 adjustable feet

Technical data and dimensions H × W × D

- Flat hinge
- Door hinged on right
- Appliance dimensions: 127.0 × 48.0 × 57.5 cm

Freestanding wine cooler

5WK 490 SL New

**Output, consumption**

- Energy consumption: 142 kWh / year
- Energy consumption: 0.493 kWh / 24 h
- Total capacity: 116 l
- Noise: 41 dB (A) re 1 pW
- Climate class: SN-ST
- Connection loads: 220–240 V / 65 W

Features, comfort

- Free standing wine cooler
- Black body & stainless steel door frame
- Touch Control
- White LED lighting
- 4 solid wood shelves
- 49-bottle capacity
- Upper part: 28 bottles (75 cl)
- Lower part: 42 bottles (75 cl)
- 2 temperature zones for sparkling, white, rosé and red wines
- Adjustable temperature ranges of use:
Upper part:/ Lower part: 5°C–20°C
- Alarm when door is open
- Optical and acoustic temperature alarm
- Electronic temperature control with precise digital reading
- UV protection
- 2-layers tempered glass with lock
- Anti-vibration system
- 2 adjustable feet

Technical data and dimensions H × W × D

- Flat hinge
- Door hinged on right
- Appliance dimensions: 84.5 × 48.0 × 57.5 cm



Technical Drawings



Gas hobs

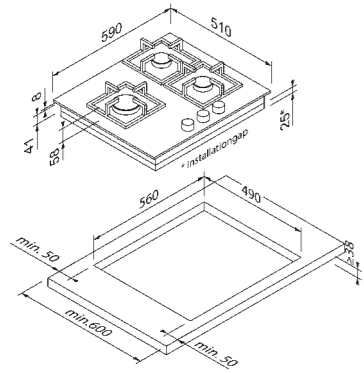

Suitable for gas hob

5GH 65BB390

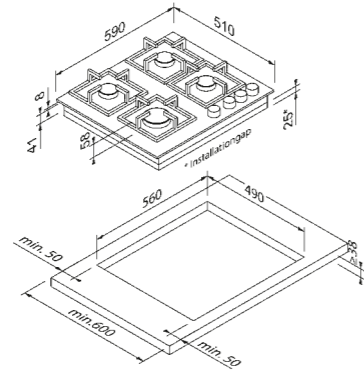

Suitable for gas hob

5GH 65BB490

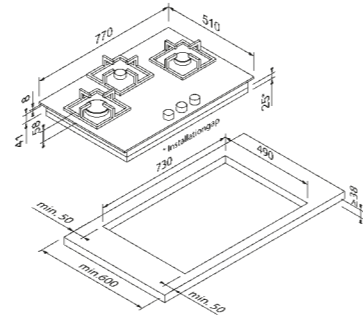

Suitable for gas hob

5GH 75BB390

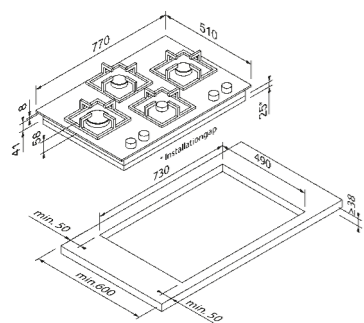

Suitable for gas hob

5GH 75BB490

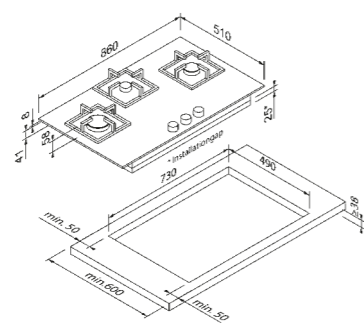

Suitable for gas hob

5GH 85BB390

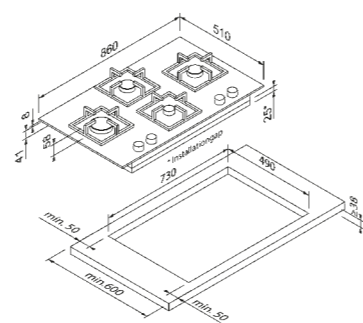

Suitable for gas hob

5GH 85BB490

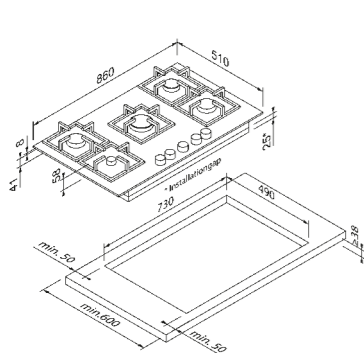

Suitable for gas hob

5GH 85BB590

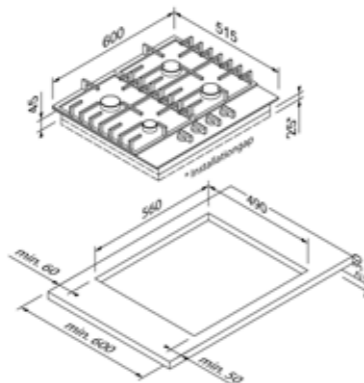

Suitable for gas hob

5GB 62191IN

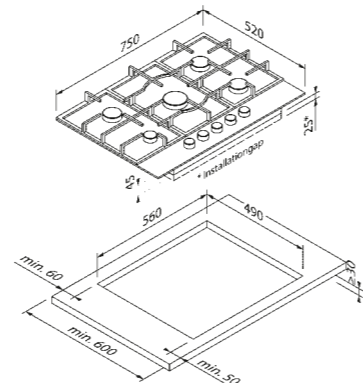

Suitable for gas hob

5GB 72290IN

Hob extractors

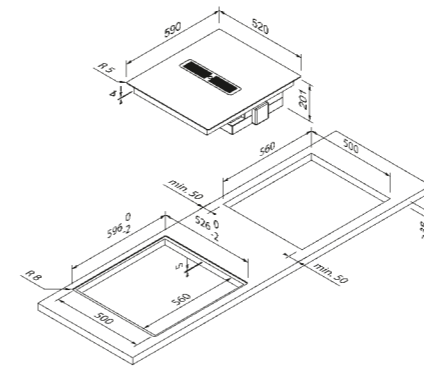

Suitable for hob extractors

5IX 60290

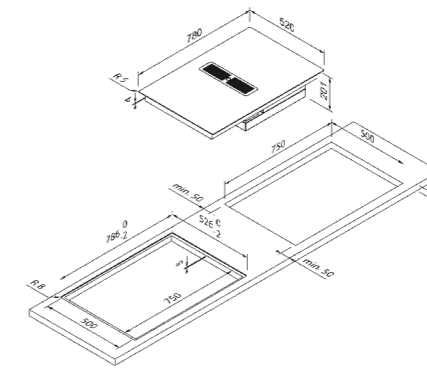

Suitable for hob extractors

5IX 80290

Island flues

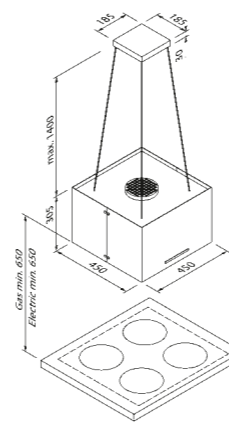

Suitable for island flue

5DB 96453

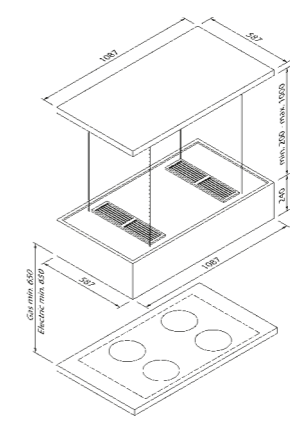

Suitable for island flue

5SL 92500

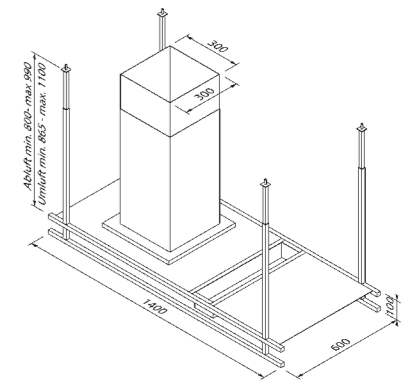

Suitable for island flue

5DF 92760

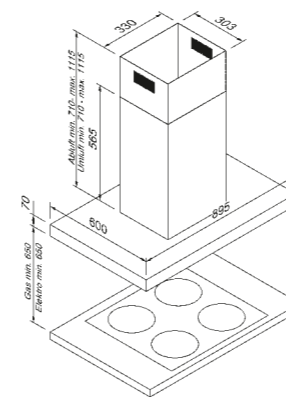

Suitable for island flue

5IT 99450

Cooling units

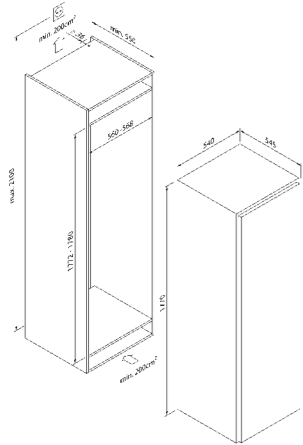

Suitable for refrigeration | 178

5CL 288FE0

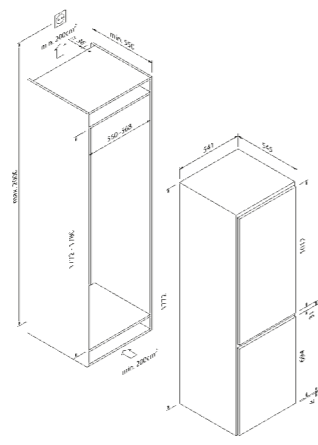

Suitable for refrigeration | 178

5CR 286FE0

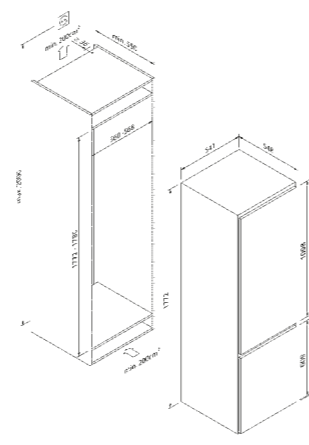

Suitable for refrigeration | 178

5CC 287FE0

Wine cooler: Undercounter

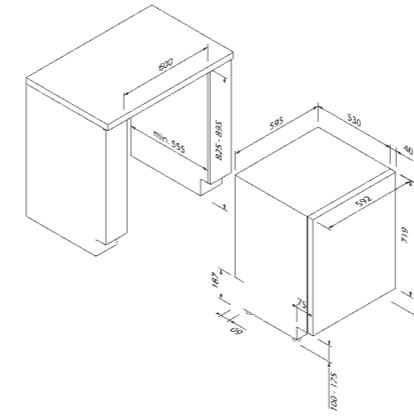

Suitable for winecooler: built under

5WK 820FF0L 5WK 820FF0R

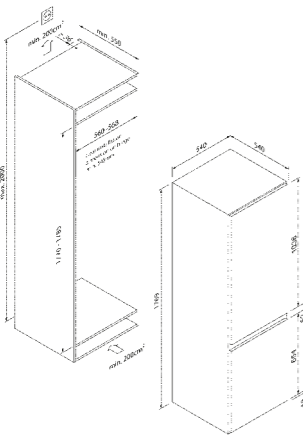

Suitable for refrigeration | 178

5CB 281FF0

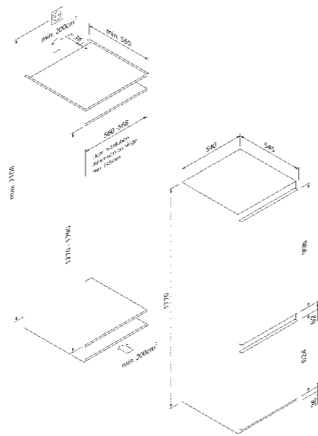

Suitable for refrigeration | 178

5CR 288FE0 5CB 288FE1

Wine cooler: Built-in

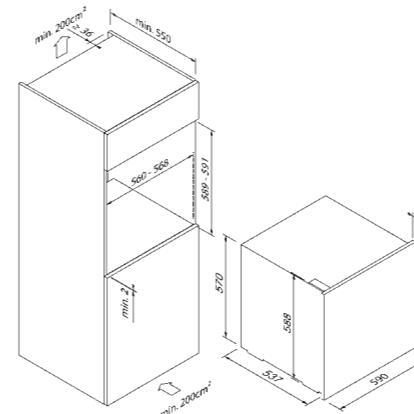

Suitable for winecooler: built-in

5WK 610FF0L

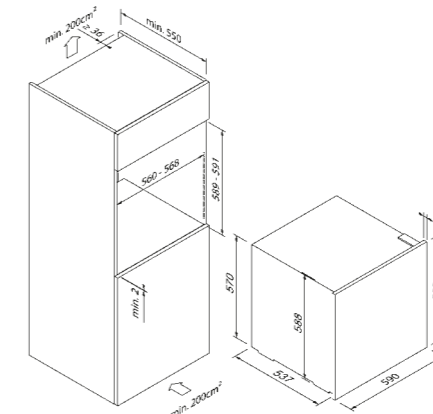

Suitable for winecooler: built-in

5WK 610FF0R

Freezer

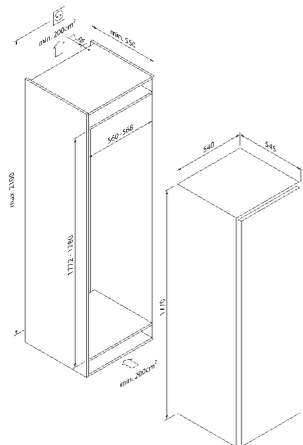

Suitable for freezer | 178

5FG 288FE0

Undercounter cooler Freestanding

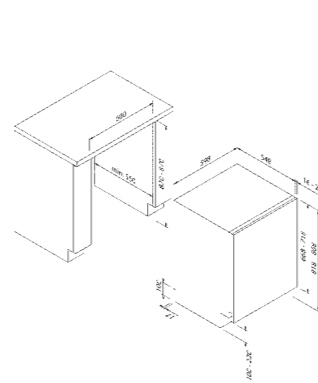

Suitable for undercounter cooler

5CP 210FF0 5CN 210FF0

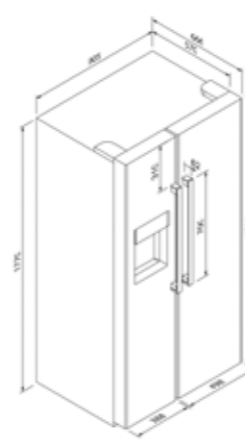

Suitable for freestanding

5SB 891SE0

Wine cooler: Freestanding

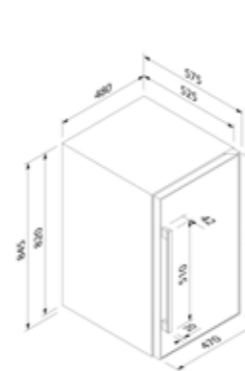

Suitable for winecooler: freestanding

5WK 490SL

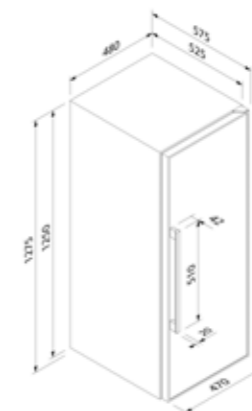

Suitable for winecooler: freestanding

5WK 750SL

Heat | Air

**Smart slider**

An intuitive, simple control concept for all appliances – every setting can be perfectly selected with the Smart Slider.

**Touch Control**

Precise, innovative and very user-friendly: gently touching the Touch Control buttons is enough to select the desired setting.

**Automatic programmes**

One touch away from the perfect result: our automatic programmes are equipped for nearly every ingredient. Cooking can't get any easier.

**Soft Moving**

Thanks to its advanced dampers and hinges, the oven door can be opened and closed smoothly. Just a light pull/push and the door opens or closes gently.

**Steam cooking**

Cooking with hot steam is gentle to the food, promises maximum taste and a healthy approach to your cooking.

**Pyrolyse**

With a simple touch, all residues from baking, frying and grilling at high temperatures are reduced to ashes that can be simply wiped away with a cloth.

**Hydrolyse**

Easy cleaning at the push of a button: With the aid of heat and steam, even strong soiling can be dissolved.

**Induction**

Immediately hot, immediately cold, and nothing gets burnt. The base of the pan is directly heated by the induction coil. The heat is only produced where it is needed. This means short heat-up times, more safety and much less energy consumption.

**Combi induction**

Two induction cooking zones can be combined together to create one single cooking zone, thereby allowing the use of very large pots and pans. Of course, the two large cooking zones can also be used separately.

**Multi Control**

The extractor fan hood and hob are intelligently linked. The extractor fan hood can be controlled separately using the hob control panel and automatically adjusts the fan power to the heat generated.

**LED**

The innovative LED lights of Blaupunkt extractor fan hoods ensure even more light on the hob. Another ray of hope: the long-lasting lights consume an extremely low amount of energy.

Water

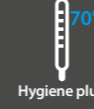
**Hygiene Plus**

An especially high short-term temperature level of 70°C for the antibacterial cleaning of dishes with especially high hygienic requirements (e.g. baby bottles) and households with allergy sufferers.

**Info Light**

The dot on the floor lights up as a visual programme indicator of when the dishwasher is in operation.

**Dosing Assistant**

Thanks to the dosing assistant, the detergent tab falls directly into a small collection tray. A targeted jet of water dissolves the tab in a quick, controlled way. The detergent is distributed uniformly throughout the machine.

**Aquastop**

A lifelong warranty against water damage. The Aquastop safety system prevents all kinds of water damage – whether on the supply hose or due to a leak in the machine.

**Vario hinges**

Vario hinges eliminate gaps between the various elements of a kitchen. The integrated furniture front moves when it is opened. This prevents the gaps between the fronts of these elements from becoming too large.

Cold

**NoFrost**

The NoFrost system drains the humidity from the freezer and prevents the formation of ice on the inner walls and hoarfrost on the food.

**Super Freezing**

With the Super Freezing function, the item is cooled down to -30°C so that newly stored food does not interrupt the freezing process.

**Big Box**

Transparent freezer drawers offer an excellent overview. A highlight: the special Big Box. It is 29 cm high and offers an enormous amount of space, e.g. for a large goose, several pizzas or large freezer portions.

**Electronic control**

With electronic temperature control, Blaupunkt refrigerations always have the right temperature. It can be read exactly at any time via the digital LED display.

**LED light**

The long-lasting LED lights are integrated flat in the side walls and illuminate the interior uniformly and perfectly.

Service



You have chosen a piece of premium kitchen equipment with Blaupunkt appliances. Our professional service is available to assist you after the purchase. Our qualified employees are pleased to remain at your disposal. Our customer service experts for Blaupunkt integrated kitchen appliances will professionally answer all questions about the appliances. Here you will receive all the information on handling, functions and performance.

**Blaupunkt built-in kitchen appliances /
customer services, repair service,
user advice, spare parts and accessories:**

**Toll free: 1800 209 2096
(office hours)**



Your direct way to Blaupunkt.
www.blaupunkt-appliances.com

www.hettich.com
customer_services@in.hettich.com

Head Office:
Hettich India Pvt Ltd.
302, Durolite House
Opp SAB TV, New Link Road
Andheri (West)
Mumbai – 400 053
Tel.: +91-22-2674 3289
Tel.: +91-22-2674 3356
Tel.: +91-22-2674 4089
Fax: +91-22-2674 3267

Registered Office:
Hettich India Pvt Ltd.
A 26 / 4, 1st Floor
Mohan Cooperative
Industrial Estate
New Delhi – 110044
Tel.: +91-011-48894000
Tel.: +91-011-48894005
Fax: +91-011-48894044

Subject to changes and delivery options as well as minor colour discrepancies in plastic parts.

® Registered trademark. © 2023 by Blaupunkt

Reproduction in part or whole only with the permission of the publisher. Printed in Germany 04 / 2023.

No liability for printing errors. Errors and technical changes reserved.

This catalogue is for specialist dealers only.